



BHADRAK ENGINEERING SCHOOL & TECHNOLOGY  
(BEST), ASURALI, BHADRAK

# Thermal Engg. II

## (Th- 04)

(As per the 2020-21 syllabus of the SCTE&VT,  
Bhubaneswar, Odisha)

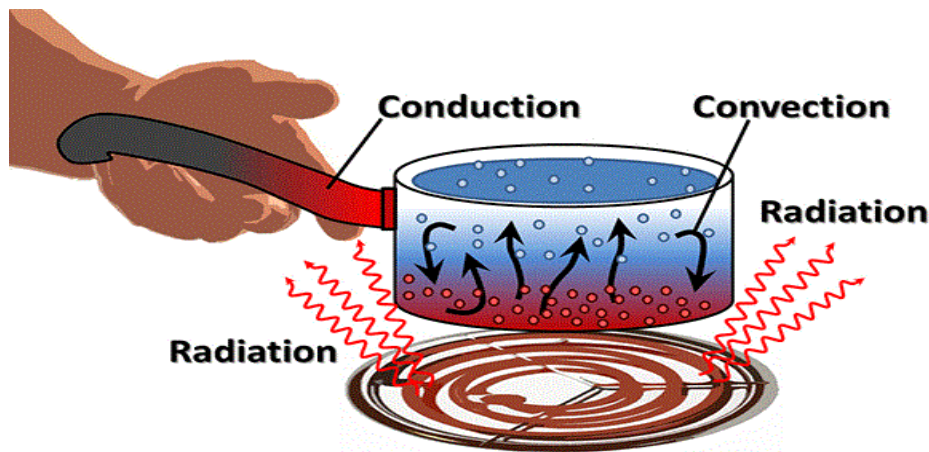

Fourth Semester

Mechanical Engg.

Prepared By: *Er S.K. Behera*

# ***Thermal Engineering -II***

## Chapter No.1

### 1. Performance of IC engine

#### 1.1 Mechanical efficiency :-

It is the ratio of the brake power and indicated power.

$$\eta_{mech} = \frac{BP}{IP}$$

It can also be expressed as

It can also be expressed as

$$\begin{aligned}\eta_{mech} &= \frac{\text{Brake thermal efficiency}}{\text{Indicated thermal efficiency}} \\ &= \frac{\eta_{bth}}{\eta_{ith}} \quad \dots(\end{aligned}$$

$$\begin{aligned}\text{and } \eta_{mech} &= \frac{\text{Brake mean effective pressure}}{\text{Indicated mean effective pressure}} \\ &= \frac{P_{mb}}{P_{mi}} \quad \dots(24.15)\end{aligned}$$

#### Indicated thermal efficiency :-

The indicated thermal efficiency is defined as the ratio of the indicated power to the heat supply rate, i.e.,

$$\eta_{ith} = \frac{IP}{\dot{m}_f \times CV}$$

### **Brake thermal efficiency :-**

The power output of an engine is obtained from the combustion of charge. Thus the overall efficiency of an engine is given by brake thermal efficiency, i.e.,

$$\eta_{bth} = \frac{\text{Brake power}}{\text{Energy supply rate}} = \frac{BP}{\dot{m}_f \times CV} \dots(24.)$$

where,  $\dot{m}_f$  = mass flow rate of the fuel (kg/s)  
 $CV$  = Calorific value of fuel, (kJ/kg)

### **Overall efficiency :-**

Overall efficiency is the ratio of the work obtained to energy supplied by fuel .

Let  $m_f$  = Mass of fuel burnt in kg per hour

$C$  = Calorific value of fuel in kJ/kg of fuel

Then, overall efficiency,

$$\begin{aligned} \eta_o &= \frac{B.P. \times 60 \times 60}{m_f \times C} \\ &= \frac{B.P. \times 3600}{m_f \times C} \end{aligned}$$

### **Relative efficiency :-**

It is the ratio of actual thermal efficiency to air standard efficiency of the engine. It is sometimes referred as efficiency ratio. It is expressed as

$$\eta_{Relative} = \frac{\text{Brake thermal efficiency}}{\text{Air standard efficiency}}$$

### **Mean effective pressure:-**

Mean effective pressure is the average pressure inside the cylinders of an IC engine based on the calculated or measured power output. It increases as manifold pressure increases. For any particular engine, operating at given speed and power output, there will be a specific indicated mean effective pressure  $i_{mep}$  and a corresponding brake mean effective pressure  $b_{mep}$ .

$$i_p = P_m L A n K / (60 \times 1000)$$

It is a hypothetical average pressure, which if acted on the piston during the entire compression stroke will require the same power input as required during the actual cycle.

Net work input in a cycle,

$$\begin{aligned} W_{in} &= p_m \times (\text{Swept volume}) \\ &= p_m \times V_s \end{aligned}$$

Thus 
$$p_m = \frac{W_{net}}{V_s} = \frac{\text{Work output}}{\text{Swept volume}} \dots(25.10)$$

From a given indicator diagram the indicated mean effective pressure can be obtained as

$$p_m = \frac{\text{Area of indicator diagram (mm}^2\text{)}}{\text{Length of the indicator diagram (mm)} \times \text{Spring constant (kPa/mm)}} \dots(25.11)$$

### **Specific Fuel Consumption :-**

It is defined as the ratio of the mass of fuel consumed per hour per unit power output (BP). It is also designated as Bsfc (brake specific fuel consumption). It is a parameter which decides the economical power production from an engine.

$$Bsfc \text{ or } sfc = \frac{\dot{m}_f \text{ (kg/h)}}{BP \text{ (kW)}} \text{ (kg/kWh)}$$

The specific fuel consumption in kg/kWh based on the indicated power (IP) is called the Isfc (indicated specific fuel consumption) and is expressed as

$$Isfc = \frac{\dot{m}_f \text{ (kg/h)}}{IP \text{ (kW)}} \text{ (kg/kWh)}$$

## **1.2 Air-Fuel Ratio (A/F) :-**

It is the ratio between the mass of the air and mass of the fuel supplied to the engine. It is expressed as

$$A/F = \frac{\dot{m}_a \text{ (mass flow rate of air)}}{\dot{m}_f \text{ (mass flow rate of fuel)}}$$

Theoretically, the correct (stoichiometric) air– fuel ratio is 15. But the combustion of air–fuel mixture can take place in A/F ratio ranges from 12 to 19 for petrol engines and 20 to 60 in Diesel engines.

## **Calorific Value :-**

The term ‘calorific value’ is most commonly used in conjunction with the combustion of fuel. The calorific value of a fuel is defined as the amount of heat energy liberated by complete combustion of unit quantity of a fuel. It is also called heating value of the fuel and it can also be considered as an absolute value of enthalpy of combustion.

That is, calorific (heating) value = | hc |

The calorific value is measured in kJ/kg or kJ/kmol for solid and liquid fuels and kJ/m<sup>3</sup> for gaseous fuels.

There are two aspects of relation for heat of formation (or reaction) and calorific value, which should be kept in mind.

1. The calorific value of the fuel is the absolute value of enthalpy of formation (or reaction), but expressed per unit quantity of fuel (i.e., reactants) rather than the products.

2. By convention, the calorific value is positive, it has opposite sign convention to that for enthalpy of formation (or reaction).

Basically, all fuels are hydrocarbons, thus their main constituents are carbon and hydrogen.

During the combustion process, carbon burns to carbon dioxide and hydrogen reacts with oxygen and forms water vapour. The magnitude of the calorific value depends on the phase of water vapour in the combustion products. When combustion products are cooled to the reactant's temperature, the water vapour gets condensed and the heat of its vaporisation is recovered.

The calorific value thus obtained is called the higher calorific value (HCV) or gross calorific value. The lower calorific value (LCV) or net calorific value is the amount of heat released by complete combustion of unit quantity of fuel, when the vapour carries its heat of vaporisation.

### **1.3 Work out problems to determine efficiency**

**Q.1** A four-cylinder, two-stroke cycle petrol engine develops 30 kW at 2500 rpm. The mean effective pressure on each piston is 8 bar and mechanical efficiency is 80%. Calculate the diameter and stroke of each cylinder, if the stroke to bore ratio is 1.5. Also calculate the fuel consumption of the engine, if the brake thermal efficiency is 28%. The calorific value of the fuel is 43900 kJ/kg.

Ans:-

**Given** A four-cylinder, two-stroke cycle petrol engine

$$\begin{aligned}k &= 4 & BP &= 30 \text{ kW} \\N &= 2500 \text{ rpm} & n &= N \\ \eta_{mech} &= 0.8 & L &= 1.5d \\ \eta_{bth} &= 0.28 & CV &= 43900 \text{ kJ/kg} \\ p_m &= 8 \text{ bar} = 800 \text{ kPa}\end{aligned}$$

**To find**

- (i) Bore of cylinder,
- (ii) Stroke of piston, and
- (iii) Fuel consumption rate (*Bsfc*).

**Analysis** The mechanical efficiency is given as

$$\eta_{mech} = \frac{BP}{IP}$$

$\therefore IP = \frac{30 \text{ kW}}{0.8} = 37.5 \text{ kW}$

- (i) The indicated power is expressed as

$$IP = \frac{p_m L A n k}{60}$$

or  $37.5 = \frac{800 \times (1.5d) \times \left(\frac{\pi}{4} d^2\right) \times 2500 \times 4}{60}$

or  $d^3 = 0.000238 \text{ m}^3$

Bore  $d = 0.062 \text{ m}$  or **62 mm**

- (ii) Stroke  $L = 1.5d = \mathbf{93 \text{ mm}}$

- (iii) The brake thermal efficiency is given by

$$\eta_{bth} = \frac{BP}{\dot{m}_f CV}$$

or  $\dot{m}_f = \frac{30 \text{ kW}}{0.28 \times (43900 \text{ kJ/kg})}$   
 $= 0.00244 \text{ kg/s}$  or  $8.78 \text{ kg/h}$

The brake specific fuel consumption

$$\begin{aligned}Bsfc &= \frac{\dot{m}_f(\text{kg/h})}{BP(\text{kW})} = \frac{8.78}{30} \\ &= \mathbf{0.293 \text{ kg/kWh}}\end{aligned}$$

**Q.2** The following results refer to a test on a petrol engine:



Indicated power = 30 kW  
brake power = 26 kW  
Engine speed = 1000 rpm  
Bsfc = 0.35 kg/kWh  
CV of fuel used = 43900 kJ/kg  
Calculate

- (a) Indicated thermal efficiency,  
(b) Brake thermal efficiency, and  
(c) Mechanical efficiency.

Ans:-

**Given** A petrol engine

$$\begin{aligned} IP &= 30 \text{ kW} & BP &= 26 \text{ kW} \\ N &= 1000 \text{ rpm} & Bsfc &= 0.35 \text{ kg/kWh} \\ CV &= 43900 \text{ kJ/kg} \end{aligned}$$

**To find**

- (i) Indicated thermal efficiency,  $\eta_{ith}$   
(ii) Brake thermal efficiency,  $\eta_{bth}$   
(iii) Mechanical efficiency,  $\eta_{mech}$

**Analysis** Fuel consumption rate,

$$\begin{aligned} \dot{m}_f &= Bsfc \times BP \\ &= 0.35 \times 26 = 9.1 \text{ kg/h} = 2.53 \times 10^{-3} \text{ kg/s} \end{aligned}$$

- (i) Indicated thermal efficiency ( $\eta_{ith}$ ),

$$\begin{aligned} \eta_{ith} &= \frac{IP}{\dot{m}_f \times CV} \\ &= \frac{30}{2.53 \times 10^{-3} \times 43900} \\ &= 0.27 = \mathbf{27\%}. \end{aligned}$$

- (ii) Brake thermal efficiency ( $\eta_{bth}$ ),

$$\begin{aligned} \eta_{bth} &= \frac{BP}{\dot{m}_f \times CV} \\ &= \frac{26}{2.53 \times 10^{-3} \times 43900} \\ &= 0.234 = \mathbf{23.4\%}. \end{aligned}$$

- (iii) Mechanical efficiency ( $\eta_{mech}$ ),

$$\eta_{mech} = \frac{BP}{IP} = \frac{26}{30} = 0.867 = \mathbf{86.7\%}.$$

Q.3 A two-stroke, Diesel engine develops a brake power of 420 kW. The engine consumes 195 kg/h of fuel and air–fuel ratio is 22:1. Calorific value of the fuel is 42000 kJ/kg. If 76 kW of power is required to overcome the frictional losses, calculate

- (a) Mechanical efficiency,
- (b) Air consumption,
- (c) Brake thermal efficiency.

Ans:-

**To find**

- (i) Mechanical efficiency,  $\eta_{mech}$
- (ii) Air consumption, and
- (iii) Brake thermal efficiency,  $\eta_{bth}$

**Analysis**

- (i) Mechanical efficiency ( $\eta_{mech}$ )

Indicated power,

$$IP = BP + FP = 420 + 76 = 496 \text{ kW}$$

$$\eta_{mech} = \frac{BP}{IP} = \frac{420}{496} = 0.8467$$

$$= \mathbf{84.67\%}.$$

- (ii) Fuel consumption rate,

$$\dot{m}_a = \dot{m}_f \times \frac{A}{F} = (195 \text{ kg/h}) \times \frac{22}{1}$$

$$= 4290 \text{ kg/h} \quad \text{or} \quad \mathbf{71.5 \text{ kg/min}}$$

- (iii) The brake thermal efficiency of an engine is expressed as

$$\eta_{bth} = \frac{BP}{\dot{m}_f \times CV}$$

$$= \frac{420 \text{ kW}}{\left(\frac{195}{3600} \text{ kg/s}\right) \times (42000 \text{ kJ/kg})}$$

$$= 0.1846 \quad \text{or} \quad \mathbf{18.46\%}$$

## QNA Chapter -1

**Q.1** What is Relative efficiency ?

It is the ratio of actual thermal efficiency to air standard efficiency of the engine. It is sometimes referred as efficiency ratio. It is expressed as

$$\eta_{Relative} = \frac{\text{Brake thermal efficiency}}{\text{Air standard efficiency}}$$

**Q.2.** What is Mechanical efficiency ?

Ans :-

It is the ratio of the brake power and indicated power.

$$\eta_{mech} = \frac{BP}{IP}$$

It can also be expressed as

It can also be expressed as

$$\begin{aligned}\eta_{mech} &= \frac{\text{Brake thermal efficiency}}{\text{Indicated thermal efficiency}} \\ &= \frac{\eta_{bth}}{\eta_{ith}} \quad \dots\end{aligned}$$

**Q.3.** Define Air-Fuel Ratio (A/F) ?

It is the ratio between the mass of the air and mass of the fuel supplied to the engine. It is expressed as

$$A/F = \frac{\dot{m}_a \text{ (mass flow rate of air)}}{\dot{m}_f \text{ (mass flow rate of fuel)}} \quad \dots$$

Theoretically, the correct (stoichiometric) air– fuel ratio is 15. But the combustion of air–fuel mixture can take place in A/F ratio ranges from 12 to 19 for petrol engines and 20 to 60 in Diesel engines.

Q.4 What do you mean by Calorific Value ?

Ans:-

The term 'calorific value' is most commonly used in conjunction with the combustion of fuel. The calorific value of a fuel is defined as the amount of heat energy liberated by complete combustion of unit quantity of a fuel. It is also called heating value of the fuel and it can also be considered as an absolute value of enthalpy of combustion

Q.5 Define Specific Fuel Consumption ?

Ans:-

It is defined as the ratio of the mass of fuel consumed per hour per unit power output (BP). It is also designated as Bsfc (brake specific fuel consumption). It is a parameter which decides the economical power production from an engine

### **Long Question**

**Q.1 .** The following results refer to a test on a petrol engine:

Indicated power = 50 kW

brake power = 25 kW

Engine speed = 1200 rpm

Bsfc = 0.35 kg/kWh

CV of fuel used = 43900 kJ/kg

Calculate Indicated thermal efficiency?

Hint –See ch.1 Q.2 solution

Q.2 A two-stroke, Diesel engine develops a brake power of 450 kW. The engine consumes 180 kg/h of fuel and air–fuel ratio is 22:1. Calorific value of the fuel is 42000 kJ/kg. If 76 kW of power is required to overcome the frictional losses, calculate Mechanical efficiency?

Hint- See ch.1 Q.3 solution

Q.3 A four-cylinder, two-stroke cycle petrol engine develops 30 kW at 2500 rpm. The mean effective pressure on each piston is 8 bar and mechanical efficiency is 80%. Calculate the diameter and stroke of each cylinder, if the stroke to bore ratio is 1.5. Also calculate the fuel consumption of the engine, if the brake thermal efficiency is 29%. The calorific value of the fuel is 45900 kJ/kg.

Hint - See ch.1 Q.1 solution

Q.4 Write a Short notes on Mean effective pressure ?

## Chapter NO.2

### 2. Air Compressor

#### 2.1 Air Compressor

- An air compressor is a machine which takes in atmospheric air, compresses it with the help of some mechanical energy and delivers it at higher pressure.
- It is also called air pump. An air compressor increases the pressure of air by decreasing its specific volume using mechanical means. Thus compressed air carries an immense potential of energy.
- The controlled expansion of compressed air provides motive force in air motors, pneumatic hammers, air drills, sand-blasting machines and paint sprayers, etc.
- The schematic of an air compressor is shown in Fig.
- The compressor receives energy input from a prime mover (an engine or electric motor).
- Some part of this energy input is used to overcome the frictional effects, some part is lost in the form of heat and the remaining part is used to compress air to a high pressure

#### Industrial use of Compressed air :-

Compressed air has wide applications in industries as well as in commercial equipment. It is used in

1. Air refrigeration and cooling of large buildings,
2. Driving pneumatic tools in shops like drills, riveters, screw drivers, etc.
3. Driving air motors in mines, where electric motors and IC engines cannot be used because of fire risks due to the presence of inflammable gases, etc.
4. Cleaning purposes,
5. Blast furnaces,
6. Spray painting and spraying fuel in Diesel engines,
7. Hard excavation work, turning, boring, mining, etc.
8. Starting of heavy-duty diesel engines,

9. Operating air brakes in buses, trucks and trains etc.
10. Inflating automobile and aircraft tyres,
11. Supercharging internal combustion engines,
12. Conveying solid and powder materials in pipelines
13. Process industries,
14. Operating lifts, hoists, crains and to operate pumps etc.
15. Pump sets for oil and gas transmission line,
16. Automobile suspension system.

## **2.2 Classification of Air compressor :-**

The compressors are mainly classified as

- (i) Reciprocating compressors, and
- (ii) Rotary compressors.

The air compressors can broadly be classified as

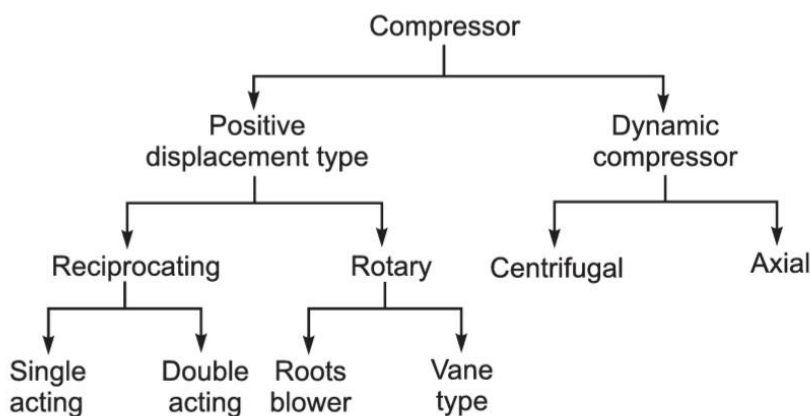

## **Operation of Air Compressor :-**

- A reciprocating compressor is used to produce high-pressure gas. It uses the displacement of piston in the cylinder for compression. It handles a low mass of gas and a high pressure ratio.
- The rotary compressors are used for low and medium pressures. They usually consist of a bladed wheel or impeller that spins inside a circular housing. They handle a large mass of

gas. These compressors may be single stage or multistage to increase the pressure ratio.

## **2.3 Parts and Working of Reciprocating Air Compressor :-**

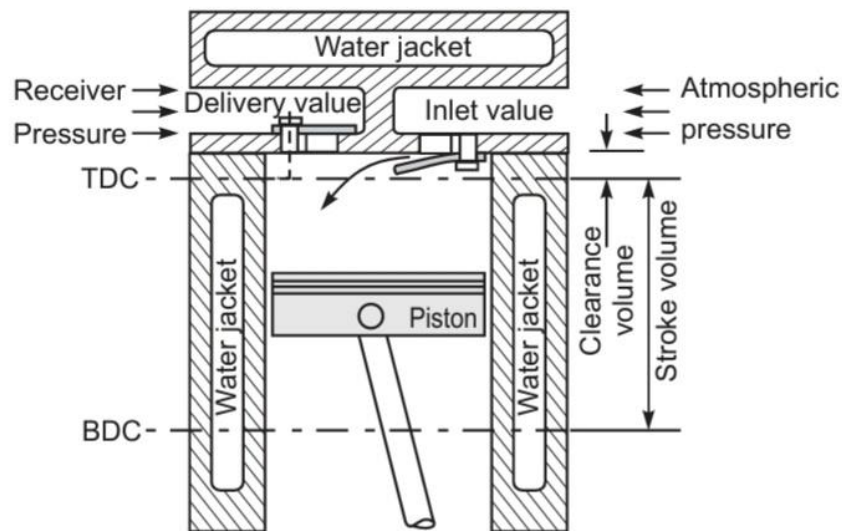

### **Sectional view of single stage reciprocating air compressor**

- Above fig, shows the sectional view of a single stage air compressor. It consists of a piston, cylinder with cooling arrangement, connecting rod, crank, inlet and delivery valves. The piston fitted with piston rings, reciprocates in the cylinder.
- The prime mover (an engine or electric motor) drives the crank shaft, the crank rotates and converts rotary motion into reciprocating motion of piston with the help of a connecting rod.
- The cylinder head consists of spring-loaded inlet and delivery valves, which are operated by a small pressure difference across them.
- The light spring pressure gives a rapid closing action. The piston rings seal the gap between the piston and cylinder wall.



- The cylinder is surrounded by a water jacket or metallic fins for proper cooling of air during compression

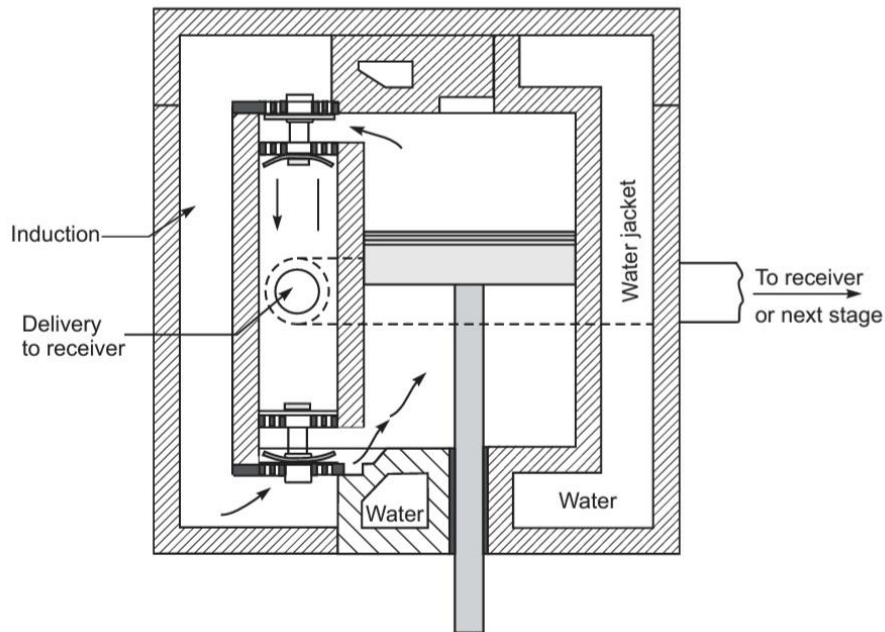

### **Double acting reciprocating air compressor**

- The double-acting air compressor is shown in above Fig . Its construction is very similar to that of a single-acting air compressor, except for two inlet and two delivery valves on two ends of the cylinder in order to allow air entry and delivery on two sides of the piston.
- When the piston compresses the air on its one side, it creates suction on the other side.
- Thus, the suction and compression of air take place on two sides of the piston simultaneously.

### **2.4 Terminology of reciprocating air compressor :-**

**Bore** :- is the inner diameter of the cylinder .

**Stroke**:- is how far the piston travels in the cylinder .

**Pressure Ratio** :- is defined as the ratio of absolute discharge pressure to absolute suction pressure.

**Free-air delivered**:- It is the discharge volume of the compressor corresponding to ambient conditions.

**Volumetric efficiency** :- The volumetric efficiency of the air compressor is defined as the ratio of actual volume of air sucked into the compressor, measured at atmospheric pressure and temperature to the piston displacement volume.

In terms of mass ratio, the volumetric efficiency is defined as the ratio of actual mass of air sucked per stroke to the mass of air corresponding to piston displacement volume at atmospheric conditions.

## 2.5 Working of single acting reciprocating air compressor :-

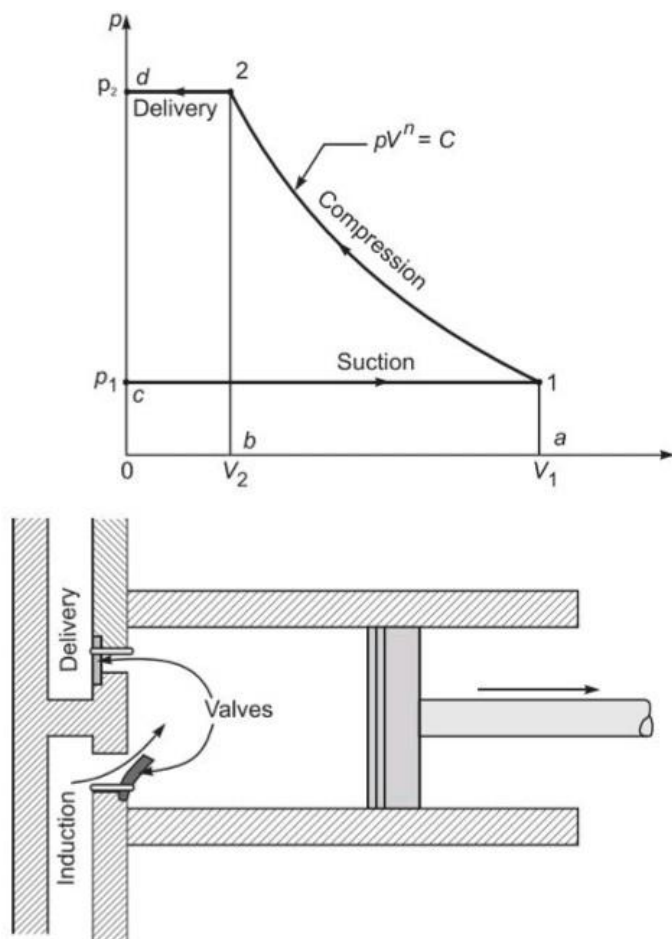

Fig. 25.4  $p$ - $V$  diagram for a reciprocating compressor without clearance

*Process c-1* Suction stroke—inlet valve opens and air enters the compressor at constant pressure  $p_1$

*Process 1-2* Polytropic compression of air from pressure  $p_1$  to pressure  $p_2$

*Process 2-d* Discharge of compressed air through delivery valve at const. pressure  $p_2$

*Process d-c* No air in the cylinder and return of piston for suction stroke

- 
- As the piston moves in a downward stroke (from TDC to BDC), any residual compressed air left in the cylinder from the previous cycle expands first.

- On further movement of the piston, the pressure in the cylinder falls below the atmospheric pressure.
  - The atmospheric air pushes the inlet valve to open and fresh air enters the cylinder as shown in Fig. 25.4. The line c-1 represents the induction stroke.
  - During this stroke, the compressed air in the storage tank acts on the delivery valve, thus it remains closed. As the piston begins its return
  - stroke from BDC to TDC, the pressure in the cylinder increases, and closes the inlet valve.
  - The air in the cylinder is compressed by piston as shown by the curve 1-2.
  - During the compression stroke, as air pressure reaches a value, which is slightly more than the pressure of compressed air acting outside the delivery valve, the delivery valve opens and the compressed air is discharged from the cylinder to storage tank.
  - At the end of the compression stroke, the piston once again moves downward, the pressure in the cylinder falls below the atmospheric pressure, the delivery valve closes and inlet valve opens for next cycle.
- The suction, compression and delivery of air take place with two strokes of the piston which is one revolution of the crank.
- Figure 25.4 shows the  $p - V$  diagram for are Reciprocating compressor without clearance.

**Indicated work for single acting reciprocating air compressor without clearance :-**

The theoretical  $p - V$  diagram for single-stage, single-acting reciprocating air compressor without clearance is shown in Fig. 25.4.

The net work done in the cycle is equal to the area behind the curve on  $p-V$  diagram and it is the work done on air.

Indicated work done on the air per cycle = Area behind the curve, i.e., area  $c-1-2-d-c$

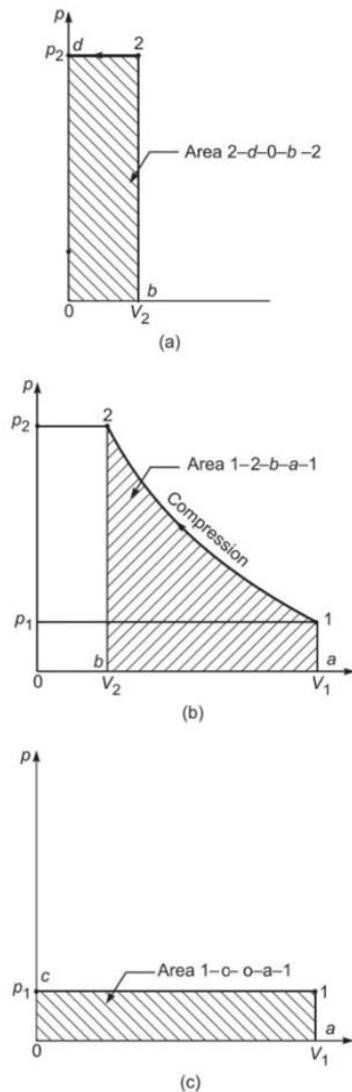

**Fig. 25.5** Three process areas on  $p-V$  diagram

$$= \text{Area } 2-d-0-b-2 + \text{Area } 1-2-b-a-1 - \text{Area } 1-c-0-a-1$$

These three areas are shown in Fig. 25.5 as (a), (b) and (c), respectively.

Area  $2-d-0-b-2 = p_2 V_2$  (Flow work during discharge at constant pressure  $p_2$ )

Area  $1-2-b-a-1 = -\int p dV$  (Piston displacement work from  $p_1$  to  $p_2$ , -

sign is taken for compression)

Area 1-c-0-a-1 =  $p_1 V_1$  (Flow work during suction at constant pressure  $p_1$ )

During compression process 1-2; the pressure and volume are related as

$$pV^n = C \text{ (constant)}$$

$$\text{Thus we get } -\int p dV = \frac{p_2 V_2 - p_1 V_1}{n-1}$$

Therefore, the total indicated work input to compressor is

$$W_{in} = p_2 V_2 + \frac{p_2 V_2 - p_1 V_1}{n-1} - p_1 V_1 \quad \dots(25.5)$$

$$= (p_2 V_2 - p_1 V_1) \left[ \frac{1}{n-1} - 1 \right]$$

$$W_{in} = \frac{n}{n-1} (p_2 V_2 - p_1 V_1) \text{ (kJ/cycle)} \quad \dots(25.6)$$

Using characteristic gas equation as

$$pV = m_a R T$$

Equation (25.6) can be modified as

$$W_{in} = \frac{n}{n-1} m_a R (T_2 - T_1) \text{ (kJ/cycle)} \quad \dots(25.7)$$

Other expression for indicated work can be derived by arranging Eq. (25.7) as

$$W_{in} = \frac{n}{n-1} m_a R T_1 \left[ \frac{T_2}{T_1} - 1 \right]$$

It is convenient to express the temperature  $T_2$  in terms of delivery and intake pressure ratio.

$$T_2 = T_1 \left( \frac{p_2}{p_1} \right)^{\frac{n-1}{n}}$$

$$\text{Then } W_{in} = \frac{n}{n-1} m_a R T_1 \left[ \left( \frac{p_2}{p_1} \right)^{\frac{n-1}{n}} - 1 \right] \text{ (kJ/cycle)} \quad \dots(25.8)$$

$$\text{or } W_{in} = \frac{n}{n-1} p_1 V_1 \left[ \left( \frac{p_2}{p_1} \right)^{\frac{n-1}{n}} - 1 \right] \text{ (kJ/cycle)} \quad \dots(25.9)$$

where  $V_1$  is the volume inducted per cycle.

## 2.6 Numericals

**Q.1** A single-stage reciprocating air compressor takes in 1.4 kg of air per minute at 1 bar and 17°C and delivers it at 6 bar. Assuming compression process follows the law  $pV^{1.35} = \text{constant}$ , calculate indicated power input to compressor.

ANS:-

**Given** A single-stage reciprocating air compressor

$$\dot{m}_a = 1.4 \text{ kg/min} \quad p_1 = 1 \text{ bar}$$

$$T_1 = 17^\circ\text{C} = 290 \text{ K} \quad p_2 = 6 \text{ bar}$$

$$n = 1.35$$

Law  $pV^{1.35} = C$

**To find** Indicator power input to compressor.

### Assumptions

- (i) Negligible clearance volume in the compressor.
- (ii) No throttling effects on valve opening and closing.
- (iii) Air as an ideal gas with  $R = 0.287 \text{ kJ/kg} \cdot \text{K}$ .

**Analysis** The delivery temperature of air

$$\begin{aligned} T_2 &= T_1 \left( \frac{p_2}{p_1} \right)^{\frac{n-1}{n}} = (290 \text{ K}) \times \left( \frac{6}{1} \right)^{\frac{1.35-1}{1.35}} \\ &= 461.46 \text{ K} \end{aligned}$$

The rate of work input to compressor, Eq. (25.7)

$$\begin{aligned} W_{in} &= \frac{n}{n-1} \dot{m}_a R (T_2 - T_1) \\ &= \frac{1.35}{1.35-1} \times (1.4 \text{ kg/min}) \times (0.287 \text{ kJ/kg} \cdot \text{K}) \\ &\quad \times (461.46 - 290) \text{ (K)} \\ &= 265.72 \text{ kJ/min} \end{aligned}$$

Indicated power input;

$$IP = \frac{W_{in}}{60} = \frac{(265.72 \text{ kJ/min})}{(60 \text{ s/min})} = \mathbf{4.43 \text{ kW}}$$

**Note:** The indicated work input to compressor can also be calculated by using Eq. (25.8).

Q.2 A single-acting, single-cylinder reciprocating air compressor has a cylinder diameter of 200 mm and a stroke of 300 mm. Air enters the cylinder at 1 bar; 27°C. It is then compressed polytropically to 8 bar according to the law  $pV^{1.3} = \text{constant}$ . If the speed of the compressor is 250 rpm, calculate the mass of air compressed per minute, and the power required in kW for driving the compressor.

Ans:-

**Given** A single-acting, single-cylinder reciprocating air compressor

$$\begin{aligned} d &= 200 \text{ mm} = 0.2 \text{ m} & L &= 300 \text{ mm} = 0.3 \text{ m} \\ p_1 &= 1 \text{ bar} = 100 \text{ kPa} & p_2 &= 8 \text{ bar} \\ N &= 250 \text{ rpm} & T_1 &= 27^\circ\text{C} = 300 \text{ K} \\ n &= 1.3 \end{aligned}$$

**To find**

- (i) The mass of air compressed in kg/min,
- (ii) Power input to compressor in kW.

**Assumptions**

- (i) Negligible clearance volume in the cylinder.
- (ii) Air as an ideal gas with  $R = 0.287 \text{ kJ/kg} \cdot \text{K}$ .

**Analysis** The swept volume of the cylinder per cycle

$$\begin{aligned} V_s &= V_1 = \left(\frac{\pi}{4}\right) d^2 L \\ &= \left(\frac{\pi}{4}\right) \times (0.2 \text{ m})^2 \times (0.3 \text{ m}) \\ &= 9.424 \times 10^{-3} \text{ m}^3 \end{aligned}$$

The mass of air, using perfect gas equation

$$\begin{aligned} m_a &= \frac{p_1 V_1}{RT_1} = \frac{(100 \text{ kPa}) \times (9.424 \times 10^{-3} \text{ m}^3)}{(0.287 \text{ kJ/kg} \cdot \text{K}) \times (300 \text{ K})} \\ &= 0.0109 \text{ kg/cycle} \end{aligned}$$



The mass flow rate of air;

$$\begin{aligned}\dot{m}_a &= \text{mass of air} \times \text{number of suction/min} = m_a N \\ &= 0.0109 \times 250 = \mathbf{2.74 \text{ kg/min}}\end{aligned}$$

Temperature of air after compression

$$\begin{aligned}T_2 &= T_1 \left( \frac{P_2}{P_1} \right)^{\frac{n-1}{n}} \\ &= (300 \text{ K}) \times \left( \frac{8}{1} \right)^{\frac{1.3-1}{1.3}} = 484.75 \text{ K}\end{aligned}$$

The work input to compressor, Eq. (25.7)

$$\begin{aligned}W_{in} &= \frac{n}{n-1} m_a R (T_2 - T_1) \\ &= \frac{1.3}{1.3-1} \times (2.74 \text{ kg/min}) \times (0.287 \text{ kJ/kg} \cdot \text{K}) \\ &\quad \times (484.75 - 300) \text{ (K)} \\ &= 629.56 \text{ kJ/min} \quad \text{or} \quad \mathbf{10.49 \text{ kW}}\end{aligned}$$

Q.3 A single-acting, single-cylinder reciprocating air compressor is compressing 20 kg/min. of air from 110 kPa, 30°C to 600 kPa and delivers it to a receiver. Law of compression is  $pV^{1.25} = \text{constant}$ . Mechanical efficiency is 80%. Find the power input to compressor, neglecting losses due to clearance, leakages and cooling.

Ans :-

**Given** A single-stage reciprocating air compressor

$$\dot{m}_a = 20 \text{ kg/min} \quad p_1 = 110 \text{ kPa}$$

$$T_1 = 30^\circ\text{C} = 303 \text{ K} \quad p_2 = 600 \text{ kPa}$$

Law  $pV^{1.25} = C$

$$\eta_{mech} = 0.8$$

**To find** Power input to compressor.

**Assumptions**

- (i) Negligible clearance volume in the compressor.
- (ii) No throttling effects on valve opening and closing.
- (iii) Air as an ideal gas with  $R = 0.287 \text{ kJ/kg} \cdot \text{K}$ .

**Analysis** The delivery temperature of air

$$T_2 = T_1 \left( \frac{p_2}{p_1} \right)^{\frac{n-1}{n}} = (303 \text{ K}) \times \left( \frac{600}{110} \right)^{\frac{1.25-1}{1.25}}$$
$$= 425.4 \text{ K}$$

The indicated power input to compressor,

$$IP = \frac{n}{n-1} \dot{m}_a R (T_2 - T_1)$$
$$= \frac{1.25}{1.25-1} \times \left( \frac{20}{60} \text{ kg/s} \right) \times (0.287 \text{ kJ/kg} \cdot \text{K})$$
$$\times (425.4 - 303) (\text{K})$$
$$= 58.55 \text{ kW}$$

The motor (brake) power

$$BP = \frac{IP}{\eta_{mech}} = \frac{58.55 \text{ kW}}{0.8} = \mathbf{73.18 \text{ kW}}$$

Q.4 A single-cylinder, double-acting, reciprocating air compressor receives air at 1 bar;  $17^\circ\text{C}$ , compresses it to 6 bar according to the law  $pV^{1.25} = \text{constant}$ . The cylinder diameter is 300 mm. The average piston speed is 150 m/min at 100 rpm. Calculate the power required in kW for driving the compressor. Neglect clearance.

Ans:-

**Given** A double-acting, single-cylinder reciprocating air compressor

$$\begin{aligned} d &= 300 \text{ mm} = 0.3 \text{ m} & p_1 &= 1 \text{ bar} = 100 \text{ kPa} \\ p_2 &= 6 \text{ bar} & N &= 100 \text{ rpm} \\ T_1 &= 17^\circ\text{C} = 290 \text{ K} & n &= 1.25 \\ k &= 2 & \mathcal{V}_{piston} &= 150 \text{ m}^3/\text{min} \end{aligned}$$

**To find** Power input to compressor in kW.

**Analysis** The piston speed is given as

$$\mathcal{V}_{piston} = 2 LN$$

Stroke of piston;

$$\begin{aligned} L &= \frac{\mathcal{V}_{piston}}{2N} = \frac{150 \text{ m}^3/\text{min}}{2 \times (100 \text{ rotation}/\text{min})} \\ &= 0.75 \text{ m} \end{aligned}$$

The swept volume of the cylinder per cycle

$$\begin{aligned} V_s = V_1 &= \left(\frac{\pi}{4}\right) d^2 L = \frac{\pi}{4} \times (0.3 \text{ m})^2 \times (0.75 \text{ m}) \\ &= 0.053 \text{ m}^3 \end{aligned}$$

The indicated work input to compressor by Eq. (25.9)

$$\begin{aligned} W_{in} &= \frac{n}{n-1} p_1 V_1 \left[ \left(\frac{p_2}{p_1}\right)^{\frac{n-1}{n}} - 1 \right] \\ &= \frac{1.25}{1.25-1} \times 100 \times 0.053 \times \left[ \left(\frac{6}{1}\right)^{\frac{1.25-1}{1.25}} - 1 \right] \\ &= 11.42 \text{ kJ/cycle} \end{aligned}$$

For a double-acting reciprocating compressor, the indicated power

$$\begin{aligned} IP &= \frac{W_{in} N k}{60} \text{ (kW)} \\ &= \frac{11.42 \times 100 \times (2 \text{ for double acting})}{60} \\ &= \mathbf{38.1 \text{ kW}} \end{aligned}$$

## QNA Chapter. 2

### Q.1 Work *of* air compressor ?

An air compressor is a machine which takes in atmospheric air, compresses it with the help of some mechanical energy and delivers it at higher pressure.

### Q.2. Write four Industrial use of Compressed air ?

Ans:-

Compressed air has wide applications in industries as well as in commercial equipment. It is used in

1. Air refrigeration and cooling of large buildings,
2. Driving pneumatic tools in shops like drills, riveters, screw drivers, etc.
3. Driving air motors in mines, where electric motors and IC engines cannot be used because of fire risks due to the presence of inflammable gases, etc.
4. Cleaning purposes,

### **Q 3** . Write the Classification of Air compressor ?

Ans:-

The compressors are mainly classified as

- (i) Reciprocating compressors, and
- (ii) Rotary compressors.

The air compressors can broadly be classified as

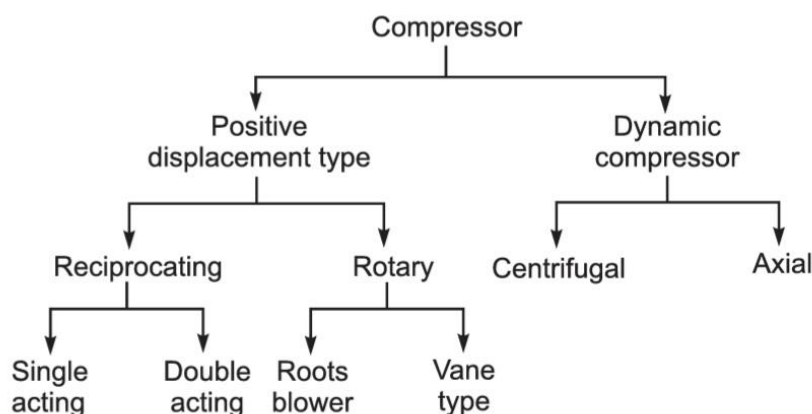

### Q.4 Define the term Pressure Ratio

Ans:- Pressure Ratio :-

**It** is defined as the ratio of absolute discharge pressure to absolute suction pressure.

**Q.5** Define Free-air delivered ?

Ans :- It is the discharge volume of the compressor corresponding to ambient conditions.

**Long questions :-**

**Q.1** A single-cylinder, double-acting, reciprocating air compressor receives air at 1 bar; 17°C, compresses it to 6 bar according to the law  $pV^{1.25} = \text{constant}$ . The cylinder diameter is 500 mm. The average piston speed is 150 m/min at 250 rpm. Calculate the power required in kW for driving the compressor. Neglect clearance.

Hint :- See numerical Solution of 4 of Ch.2

**Q.2** A single-acting, single-cylinder reciprocating air compressor is compressing 30 kg/min. of air from 110 kPa, 30°C to 600 kPa and delivers it to a receiver. Law of compression is  $pV^{1.25} = \text{constant}$  Mechanical efficiency is 80%. Find the power input to compressor, neglecting losses due to clearance, leakages and cooling

*Hint* - See numerical Solution no.3 of Ch.2

**Q.3** A single-acting, single-cylinder reciprocating air compressor has a cylinder diameter of 200 mm and a stroke of 300 mm. Air enters the cylinder at 1 bar; 27°C. It is then compressed polytropically to 8 bar according to the law  $pV^{1.3} = \text{constant}$ . If the speed of the compressor is 250 rpm, calculate the mass of air compressed per minute, and the power required in kW for driving the compressor

Hint - - See numerical Solution no.2 of Ch.2

**Q.4** A single-stage reciprocating air compressor takes in 2.5 kg of air per minute at 1 bar and 17°C and delivers it at 6 bar. Assuming compression process follows the law  $pV^{1.35} = \text{constant}$ , calculate indicated power input to compressor.

Hint - - See numerical Solution no.1 of Ch.2

## Chapter No.3

### 3.Properties of Steam

#### 3.1 Difference between gas and steam ?

The main difference between steam and gas is that the steam state of a substance in which evaporation is not complete from its liquid state. Gas is a state in which there is complete vaporization of the liquid. It is a gaseous state.

#### 3.2 Formation of steam :-

Consider a cylinder fitted with a frictionless piston, which may be loaded to any desired pressure. The cylinder contains 1 kg of ice at  $-10^{\circ}\text{C}$  under 1 atm pressure at the state A as shown in Fig. 3.3. The stages of heat addition are illustrated in Fig. below. Process A B When any amount of heat is added to ice, it gets warmer and its temperature rises till it approaches  $0.01^{\circ}\text{C}$  (generally referred as  $0^{\circ}\text{C}$ ) as shown by the line AB in Fig..

Process B C The following facts are observed during this process:

- (i) Ice begins to melt at  $0^{\circ}\text{C}$  and a two-phase mixture is formed.
- (ii) The temperature of the two-phase mixture (M1) of ice and water does not change on heat addition as it is shown by the line BC.
- (iii) There is slight decrease in volume because the liquid water at  $0^{\circ}\text{C}$  is heavier than ice.
- (iv) At the point C, all ice melts to water without change in pressure (1 atm) and temperature ( $0^{\circ}\text{C}$ )..

This phase transformation from solid to liquid is called the melting or fusion of ice.

Process C D When heat is added to liquid water, the following facts are observed:

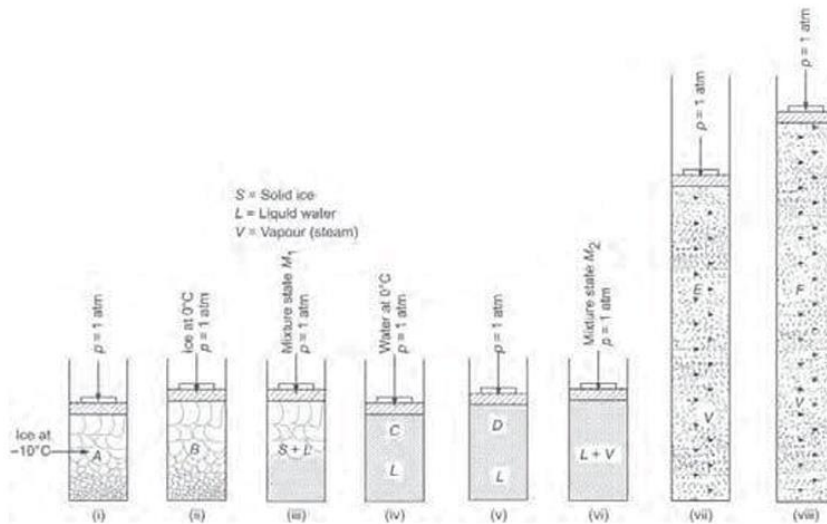

Fig. 3.3 Water in different thermodynamic states

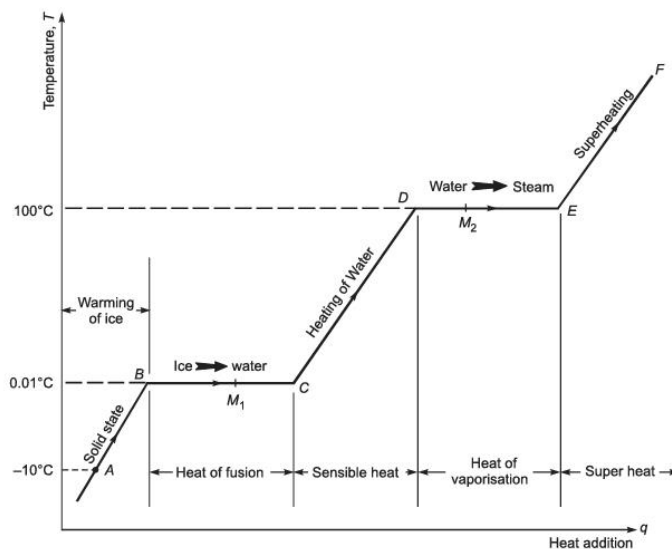

Fig. 3.4 Phase-change process of water

(i) The temperature of water rises with heat supply and keeps on rising until it reaches boiling point temperature, the point D.

(ii) There is decrease in the specific volume of water, when its temperature rises from 0°C to 4°C and thereafter, the specific volume increases with temperature rise till it reaches the saturation temperature. The piston moves up slightly during this process as shown in Fig. 3.3. (v).

(iii) The pressure in the cylinder remains constant at 1 atm.

Process D–E After water reaches saturation temperature (i.e., 100°C at 1 atm), any addition of heat will cause some liquid to vaporise at the same temperature. This is again a phase-change process from

saturated water to saturated vapour. During this phase-change process, the following facts are observed:

- (i) There exists a two-phase mixture M2 of water and vapour, called the wet steam.
- (ii) The temperature of the mixture remains constant until all water does not convert into vapour (steam).
- (iii) The process of phase change takes place at constant temperature and constant pressure.
- (iv) The specific volume of vapour is considerable larger than that of saturated water as shown in Fig. 3.3 (vii). At the state E, all the water has been vaporised and this state of steam is called dry and saturated steam. The phase change from liquid to vapour is called vaporisation. Process E F Once the steam becomes dry and saturated, it behaves as an ideal gas and its temperature and volume start increasing with further supply of heat. This steam is called superheated steam.

### 3.3 Representation on P-V ,T-S ,H-S ,and T-H :-

**P-V :-** The overall shape of a p–v diagram of a pure substance is very similar to a T–v diagram, except that the constant temperature lines on this diagram have a downward trend. A pressure-specific volume (p–v) diagram for water is shown

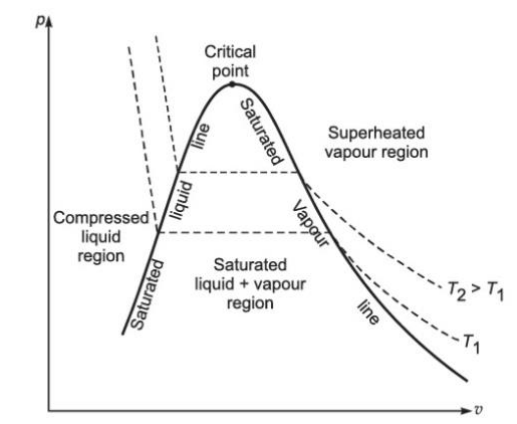



**T-S:-** The temperature–entropy (T–s) diagram of a pure substance is shown in Fig. below with the following observations:

1. The absolute temperature data is plotted along the ordinate, and the specific entropy data is plotted along the abscissa.
2. The value of specific entropy at triple point is zero, and thus the saturated liquid line originates at a temperature of 273.16 K
3. The saturated liquid line and saturated vapour line divide the diagram into three regions, i.e., compressed liquid region left to the saturated liquid line, superheated vapour region right to the saturated vapour line and the wet vapour region between these two lines. The two saturation lines meet at the critical point.
4. In the compressed liquid region, the constant- pressure lines almost coincide with the saturated liquid line.
5. In the saturated liquid–vapour mixture region, the constant pressure lines and constant temperature lines are horizontal and parallel to each other.
6. In the superheated vapour region, the constant volume lines are steeper than the constant pressure lines.

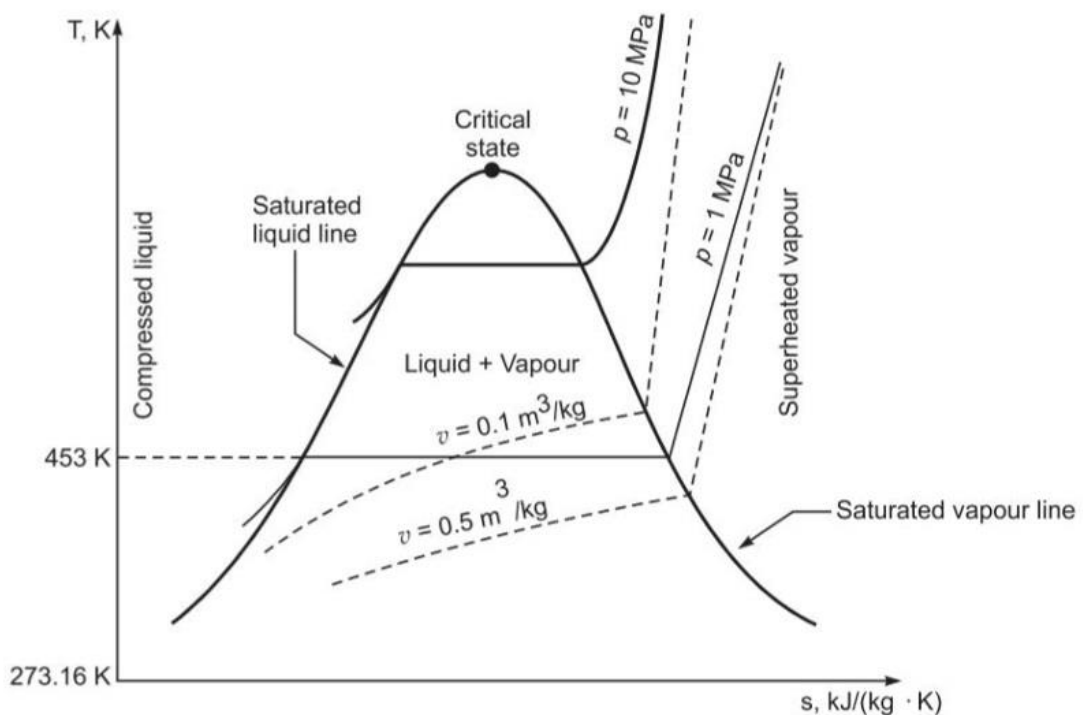

**H-S :-** The enthalpy–entropy diagram is referred as Mollier diagram. It is most commonly used to obtain the properties of steam with reasonable accuracy, while analysing the steady flow devices such as a steam turbines, nozzles, etc. The use of a Mollier chart eliminates the complex calculation work and it is also convenient to use. In the enthalpy–entropy chart, the enthalpy is plotted against entropy. The h–s chart covers a pressure range from 0.01 bar to 1000 bar and a temperature up to 800°C. The lines of constant dryness fraction are drawn in the wet region to the value less than 0.5. The lines of constant temperature are drawn in the superheated region. The h–s chart does not show the value of specific enthalpy, specific entropy and specific volume for saturated water at pressures which are generally associated with a steam condenser. Hence, this chart is only useful during the expansion process of a steam cycle.

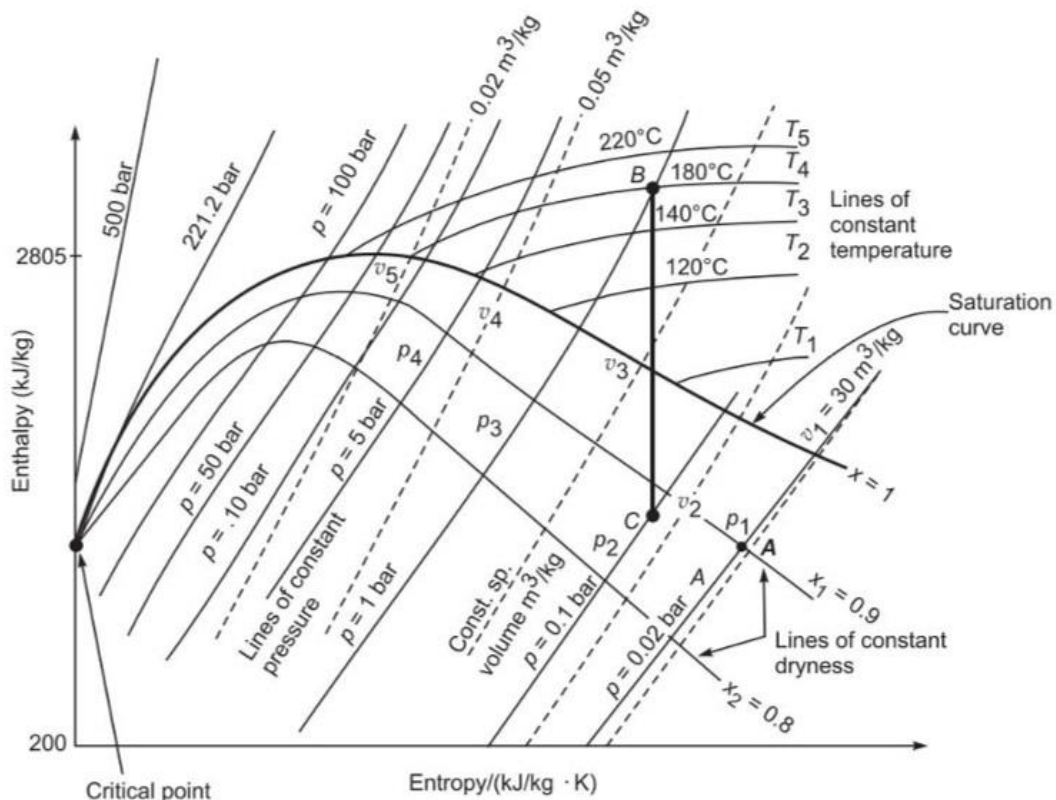

### **3.4 Definition and properties of steam :-**

**1.Vaporisation :-** It is the process that involves change of phase from liquid to vapour, when the latent heat of phase change is supplied to saturated water.

**2. Evaporation** It is the process of vapour generation only at the free surface of the liquid. The molecules at the free surface extract their latent heat of phase transformation from the surrounding medium and break away as vapour from the liquid surface and escape to the surrounding atmosphere.

**3. Boiling** It is the phenomenon of vapour formation in the whole mass of liquid, when heat is supplied.

**4. Saturation Temp.** It is the temperature at which a pure substance starts to evaporate at a given pressure.

**5. Saturation Pressure** It is the pressure at which a pure substance starts to evaporate at a given temperature.

**6.Steam** It is the gases phase of water.

**7. Saturated Steam** The steam is about to condense.

**8. Wet Steam** It is the mixture of dry steam and water particles as moisture.

**9.Dryness Fraction** It is a measure of quality of wet steam.

**10. Dry Saturated Steam** Saturated vapour, which is free from moisture.

**11. Superheated Steam** The steam existing at higher temperature than its saturation temperature.

**12. Degree of Super heat** It is the temperature rise of superheated steam above its saturation temperature.

**13. Critical Point** A locus on the saturation curve, where saturation liquid line and saturated vapour line meet.

**14.Triple Point** A locus on the p–T diagram, where

all three phases of water coexist.

### Properties of Steam :-

## Properties of steam

### 1. Enthalpy or Total heat of water ( $h_f$ )

- It is defined as the quantity of heat required to raise the temperature of one kg of water from 0 C to it's boiling point or saturation temperature corresponding to the pressure applied. It is also called enthalpy of saturated water or liquid heat and is represented by  $h_f$ .

$$\begin{aligned} H_f &= \text{specific heat of water}(c_{pw}) \times \text{rise in temperature} \\ &= 4.187 \times \Delta t, \text{ kJ/kg} \end{aligned}$$

## Properties of steam

### 2. Enthalpy of wet steam

- It may be defined as the quantity of heat required to convert one kg of water at 0 C, at constant pressure, into wet steam.

$$h = h_f + x h_{fg}$$

When steam is dry saturated, then  $x = 1$

and

$$h = h_f + x h_{fg}$$

### 3. Latent heat of steam ( $h_{fg}$ )

- Latent heat of steam at a particular pressure may be defined as a quantity of it required to convert one kg of water at it's boiling point into dry steam at the same pressure. It is denoted by  $h_{fg}$ .

## Properties of steam

### 4. Dryness fraction (x)

➤ It is defined as the ratio mass of dry steam actually present to the mass of wet steam. It is denoted by x.

➤ Let  $m_s$  = mass of dry steam, kg  
 $m_w$  = mass of water vapour in steam, kg  
x = dryness fraction of the sample

then,

$$x = \frac{m_s}{m_s + m_w}$$

for dry steam,

$$m_w = 0 \text{ and } x = 1$$

➤ The quality of steam is the dryness fraction expressed as a percentage.

## Properties of steam

➤ Wetness fraction =  $1 - x = \frac{m_w}{m_s + m_w}$

The wetness fraction expressed in percentage is called priming.

### 5. Total Enthalpy of Superheated Steam

➤ Let  $c_{ps}$  = specific heat of superheated steam  
 $t_s$  = temperature of formation of steam, C  
 $t_{sup}$  = temperature of superheated heat, C

➤ Then heat of superheated steam

$$\begin{aligned} h_{sup} &= c_{ps}(t_{sup} - t_s) \\ &= (h_f + h_{fg}) + c_{ps}(t_{sup} - t_s) \\ &= h_g + c_{ps}(t_{sup} + t_s) \end{aligned}$$

## 3.5 Use of Steam Table and Mollier Chart :-

### Use of Steam Table :-

The laws of perfect gases are not applicable to vapours, hence the variation between their properties are obtained from charts and tables. Experimentally determined thermodynamic properties of water are presented in three different forms of tables as follows: In this table, temperature is chosen as an independent variable and properties of coexisting liquid and vapour phases are presented for saturated water/steam.

1. The steam table gives the properties on per kg basis. For the different masses they should be multiplied by the given mass.
2. If the value of the independent property of the column 1, i.e., temperature or pressure is not included in steam tables, the properties should be obtained by linear interpolation.
3. A meagre negligible variation in answers is inevitable due to usage of different steam tables.
4. In case the nature of pressure is not specified, it should be assumed absolute pressure
5. The steam tables give the values of properties above 0°C. Hence if the initial temperature of water is other than 0°C then the initial enthalpy of water can be obtained from the temperature entry steam table at a given temperature. The enthalpy of fluid is then obtained by deducting the initial enthalpy from the total enthalpy of steam.

**USE:-**

1. It is capable to supply process heat at constant temperature while condensing.
2. It is cheap, and can be produced everywhere.
3. It is a clean, odourless and tasteless source of heat energy
4. It can be used repeatedly again and again as well as first used for power generation and then for process heating.
5. Its flow rate can easily be controlled and readily distributed

**Mollier diagram. :-**

enthalpy–entropy diagram is referred as Mollier diagram. It is most commonly used to obtain the properties of steam with reasonable accuracy, while analysing the steady flow devices such as a steam turbines, nozzles, etc. The use of a Mollier chart eliminates the complex calculation work and it is also convenient to use.

In the enthalpy–entropy chart, the enthalpy is plotted against entropy. The h–s chart covers a pressure range from 0.01 bar to 1000 bar and a temperature up to 800°C. The lines of constant dryness fraction are drawn in the wet region to the value less than 0.5. The lines of constant temperature are drawn in the superheated region.

The  $h$ - $s$  chart does not show the value of specific enthalpy, specific entropy and specific volume for saturated water at pressures which are generally associated with a steam condenser. Hence, this chart is only useful during the expansion process of a steam cycle.

A schematic for  $h$ - $s$  diagram is shown in

Fig. below . The constant pressure lines are indicated by  $p_1, p_2, p_3 \dots$ , etc., the constant temperature lines by  $T_1, T_2, T_3 \dots$ , etc., the constant dryness fraction lines by  $x_1, x_2, x_3 \dots$ , etc., and the constant volume lines are drawn dotted lines as indicated by  $v_1, v_2, v_3 \dots$ , etc.

Any two independent properties which appear on the chart are sufficient to define the state of steam. In the wet region, the pressure  $p_1$  and the dryness fraction  $x_1$  define the state A. In the superheated region, the pressure  $p_3$  and the temperature  $T_4$  define the state B. A vertical line BC of constant entropy can easily be drawn between the pressure  $p_3$  and the pressure  $p_2$  to obtain state C. It consists of the following features:

1. The constant temperature lines are straight and almost horizontal in the superheated vapour region specially at low pressures.
2. The lines of constant dryness fraction ( $x$ ) are also shown in the diagram, which are parallel to the saturation line.
3. The constant-pressure lines do not change their shape in either region because for a constant-pressure process;
4. The constant-volume lines are steeper than constant-pressure lines.
5. The compressed-liquid region is not shown in the diagram

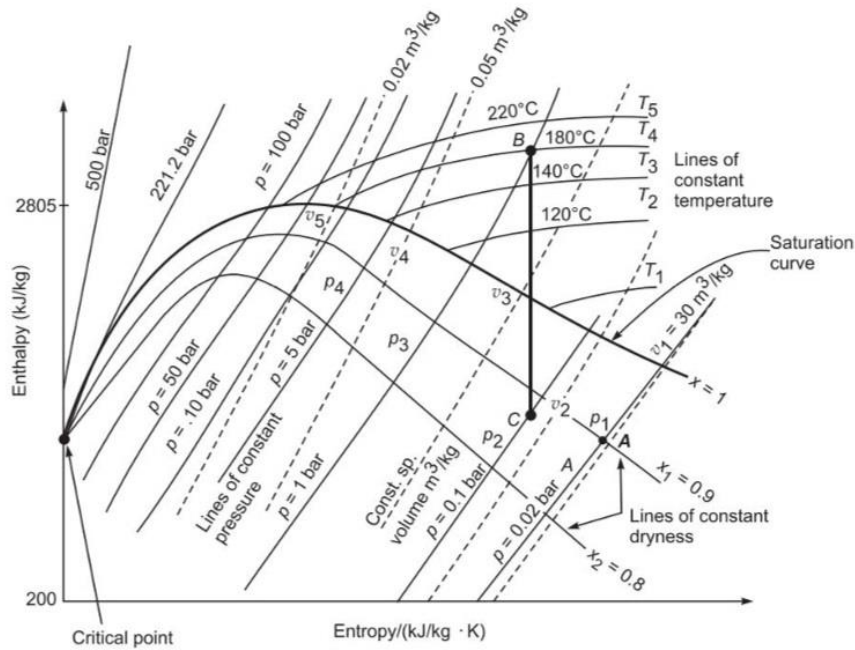

Mollier diagram

### 3.6 Flow and Non flow process of Vapours :-

Equations for ideal gases as  $p v = RT$ , Joule's law, etc., are not applicable to vapour, though the basic energy equations derived from the first law are applicable. Equations related with work done, heat transfer, enthalpy, internal energy do apply to vapour under specified conditions. The following basic-energy equation can be applied to vapour by taking care of units. For a unit mass system;

Heat transfer;  $\delta q = T ds$   
 $\delta q = du + p dv$   
 and  $\delta q = dh - v dp$   
 Internal energy;  $u = h - pv$   
 Work transfer;  $w = \int_1^2 p dv$

The unknown state property can be obtained by equating constant property between two states of a process, as given:

For constant-volume process;  $v_1 = v_2$   
 For isentropic process;  $s_1 = s_2$   
 For isothermal process;  $p_1 v_1 = p_2 v_2$   
 For polytropic process;  $p_1 v_1^n = p_2 v_2^n$



### 3.7 P-V ,T-S ,H-S diagram

**P-V :-** The overall shape of a p–v diagram of a pure substance is very similar to a T–v diagram, except that the constant temperature lines on this diagram have a downward trend. A pressure-specific volume (p–v) diagram for water is shown

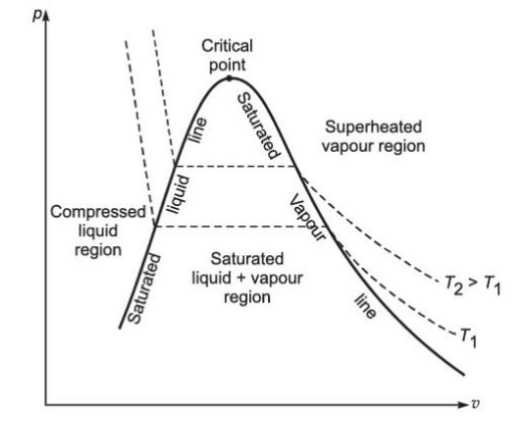

**T-S:-** The temperature–entropy (T–s) diagram of a pure substance is shown in Fig. bellow

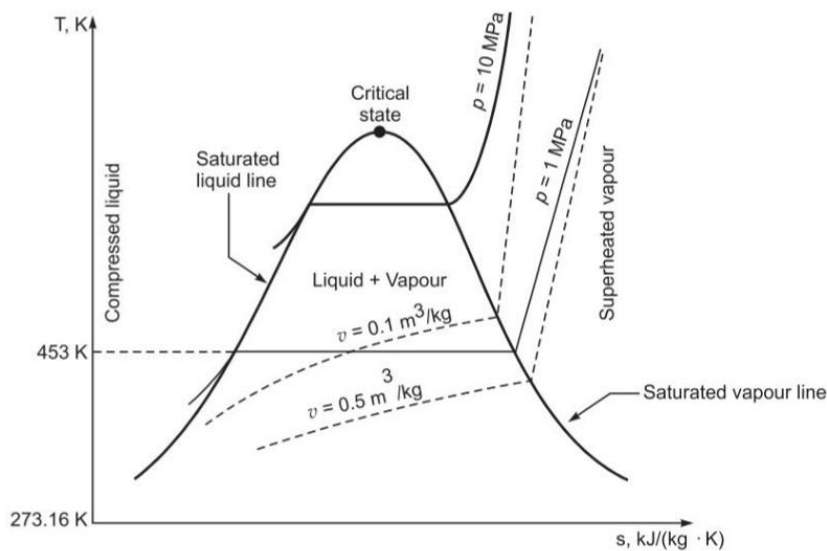

**H-S :-** The enthalpy–entropy diagram is referred as Mollier diagram. It is most commonly used to obtain the properties of steam with reasonable accuracy, while analysing the steady flow devices such as a steam turbines, nozzles, etc. The use of a Mollier chart eliminates the complex calculation work and it is also convenient to use. In the enthalpy–entropy chart, the enthalpy is plotted against entropy .

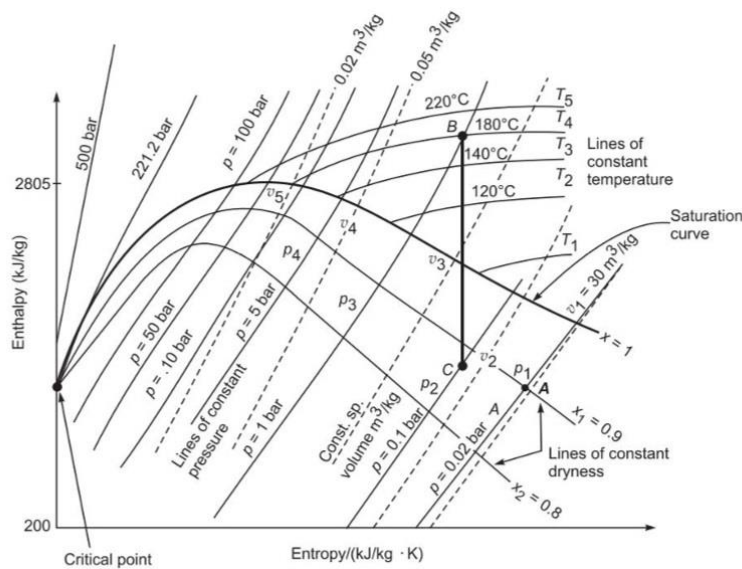

### 3.7 Properties changes with numerical

Q.1 Calculate volume, density, enthalpy, and entropy of 2 kg of steam at 80°C and having a dryness fraction of 0.85.

Ans:-

**Given** Wet steam

$$m = 2 \text{ kg} \quad T = 80^\circ\text{C} \quad x = 0.85$$

**To find**

- (i) Volume, (ii) Density,  
(iii) Enthalpy, and (iv) Entropy.

**Properties of water** At  $80^\circ\text{C}$ ;

$$\begin{aligned} p_{sat} &= 47.39 \text{ kPa} & v_f &= 0.001029 \text{ m}^3/\text{kg} \\ v_g &= 3.40715 \text{ m}^3/\text{kg} & h_f &= 334.88 \text{ kJ/kg} \\ h_{fg} &= 2308.77 \text{ kJ/kg} \cdot \text{K} & s_f &= 1.0752 \text{ kJ/kg} \cdot \text{K} \\ s_{fg} &= 6.5369 \text{ kJ/kg} \cdot \text{K} \end{aligned}$$

**Analysis**

- (i) At  $80^\circ\text{C}$ , the specific volume of steam;

$$\begin{aligned} v &= (1-x)v_f + xv_g \approx xv_g \\ &= 0.85 \times 3.40715 = 2.896 \text{ m}^3/\text{kg}, \end{aligned}$$

For  $m = 2 \text{ kg}$ ;

$$V = m v = 2 \times 2.896 = \mathbf{5.792 \text{ m}^3}$$

- (ii) The density of steam;

$$\rho = \frac{1}{v} = \frac{1}{2.896} = \mathbf{0.345 \text{ kg/m}^3}$$

- (iii) Specific enthalpy of steam;

$$\begin{aligned} h_{wet} &= h_f + xh_{fg} = 334.88 + 0.85 \times 2308.77 \\ &= 2297.33 \text{ kJ/kg} \end{aligned}$$

Total enthalpy

$$H = m h_{wet} = 2 \times 2297.33 = \mathbf{4594.66 \text{ kJ}}$$

- (iv) Specific entropy of steam;

$$\begin{aligned} s_{wet} &= s_f + xs_{fg} = 1.0752 + 0.85 \times 6.5369 \\ &= 6.631 \text{ kJ/kg} \cdot \text{K} \end{aligned}$$

Total entropy

$$S = m s_{wet} = 2 \times 6.631 = \mathbf{13.26 \text{ kJ/K}}$$

Q.2 Calculate volume, density, enthalpy, and entropy of 2 kg of water at 2 bar and  $80^\circ\text{C}$ . ?

Ans :-

**To find**

- (i) Volume, (ii) Density,  
(iii) Enthalpy, and (iv) Entropy.

**Assumption** The specific heat of water as 4.187 kJ/kg·K.

**Properties of water** At  $T = 80^\circ\text{C}$

$$p_{sat} = 47.39 \text{ kPa}$$
$$v_f = 0.001029 \text{ m}^3/\text{kg}$$

**Analysis** At  $80^\circ\text{C}$ , water pressure is 2 bar, thus it is compressed liquid.

- (i) At  $80^\circ\text{C}$ , the specific volume of water

$$v_f = 0.001029 \text{ m}^3/\text{kg}$$

For  $m = 2 \text{ kg}$ ;

$$V = m v_f = 2 \times 0.001029 = \mathbf{0.002058 \text{ m}^3}$$

- (ii) The density of water

$$\rho = \frac{1}{v_f} = \frac{1}{0.001029} = \mathbf{971.82 \text{ kg/m}^3}$$

- (iii) The enthalpy of water

$$H = m C_{pw} (T_{water} - 0)$$
$$= 2 \times 4.187 \times (80^\circ\text{C} - 0) = \mathbf{669.92 \text{ kJ}}$$

- (iv) Entropy of water

$$S = m C_{pw} \ln \left( \frac{T_{water} + 273}{0 + 273} \right)$$
$$= 2 \times 4.187 \times \ln \left( \frac{80 + 273}{0 + 273} \right) = \mathbf{2.152 \text{ kJ/K}}$$

Q.3 Identify the type of steam in the following three cases, using the steam tables and giving

necessary calculations supporting your claim.

(a) 2 kg of steam at 8 bar with an enthalpy of 5538.0

kJ at a temperature of 170.4°C

(b) 1 kg of steam at 2550 kPa occupies a volume of 0.2742 m<sup>3</sup>. Also, find the steam temperature.

(c) 1 kg of steam at 60 bar with an enthalpy of 2470.73 kJ/kg.

ANS :-

**Case (i): Given** The steam

$$m = 2 \text{ kg}$$

$$p = 8 \text{ bar}$$

$$H = 5538 \text{ kJ}$$

$$T_{sat} = 170.4^\circ\text{C}$$

**To find** Quality of steam.

**Analysis** The properties of steam at 8 bar;

$$T_{sat} = 170.4^\circ\text{C}$$

$$h_f = 721.1, \text{ kJ/kg}$$

$$h_{fg} = 2048.04 \text{ kJ/kg}$$

$$h_g = 2769.13 \text{ kJ/kg}$$

The specific enthalpy of a given mass of steam

$$h = \frac{H}{m} = \frac{5538}{2} = 2769.0 \text{ kJ/kg}$$

The specific enthalpy of given steam is approximately equal to the total enthalpy of vapour at saturation temperature, and therefore, the given sample of steam is **dry and saturated**.

**Case (ii): Given** The steam

$$m = 1 \text{ kg}$$

$$p = 2550 \text{ kPa}$$

$$v = 0.2742 \text{ m}^3$$

**To find** Quality of steam.

**Analysis** The properties of steam at 2550 kPa

$$T_{sat} = 225^\circ\text{C}$$

$$v_g = 0.07835 \text{ m}^3/\text{kg}$$

The given volume of steam is more than the volume of vapour at saturation temperature. Therefore,

$$v = v_g \times \frac{T_{sup}}{T_{sat}}$$

-

or  $0.2742 = 0.07835 \times \frac{T_{sup}}{(225 + 273)}$

or  $T_{sup} = 1742.84 \text{ K} = \mathbf{1469^\circ\text{C}}$

The given sample of steam is **superheated**.

**Case (iii): Given** The steam

$$m = 1 \text{ kg} \quad p = 60 \text{ bar} \quad h = 2470.73 \text{ kJ/kg}$$

**To find** Quality of steam.

**Analysis** The properties of steam at 60 bar

$$\begin{aligned} T_{sat} &= 275.64 \text{ }^\circ\text{C} & h_f &= 1213.32 \text{ kJ/kg} \\ h_{fg} &= 1571.0 \text{ kJ/kg} & h_g &= 2784.33 \text{ kJ/kg} \end{aligned}$$

The enthalpy of the given steam is less than the total enthalpy of steam at saturation temperature. Therefore,

$$h = h_f + x h_{fg}$$

or  $2470.73 = 1213.32 + x \times 1571.0$

or  $x = \mathbf{0.8}$

The given sample of steam is **wet**.

### **QNA CH.3**

Q.1 Write Difference between gas and steam ?

Ans:-

The main difference between steam and gas is that the steam state of a substance in which evaporation is not complete from its liquid state. Gas is a state in which there is complete vaporization of the liquid. It is a gaseous state.

Q.2 . Define Vaporisation\_ ?

Ans :- It is the process that involves change of phase from liquid to vapour, when the latent heat of phase change is supplied to saturated water.

**Q.3** What is Evaporation ?

Ans:- It is the process of vapour generation only at the free surface of the liquid. The molecules at the free surface extract their latent heat of phase transformation from the surrounding medium and break away as vapour from the liquid surface and escape to the surrounding atmosphere

Q.4 Define Triple Point ?

Ans :-A locus on the p–T diagram, where all three phases of water coexist.

Q.5 What is Critical Point ?

Ans:- A locus on the saturation curve, where saturation liquid line and saturated vapour line meet

### **Long Questions**

**Q.1** Identify the type of steam in the following three cases, using the steam tables and giving necessary calculations supporting your claim.

5 kg of steam at 8 bar with an enthalpy of 5538.0 kJ at a temperature of 170.4°C

Hint – See solution no.3 of ch .3

Q.2 . Calculate volume, density, enthalpy, and entropy of 5 kg of water at 2 bar and 80°C. ?

Hint – See Solution no 2 of ch.3

Q.3 Calculate volume, density, enthalpy, and entropy of 2 kg of steam at 80°C and having a dryness fraction of 0.85.

Hint - See Solution no 1 of ch.3



## Chapter no.4

### Steam Generator

#### 4.1 Classification & types of Boiler

- ❖ In simple a **boiler** may be defined as a closed vessel in which steam is produced from water by combustion of fuel.
- ❖ According to American Society of Mechanical Engineers (A.S.M.E.) a 'steam generating unit' is defined as :  
"A combination of apparatus for producing, furnishing or recovering heat together with the apparatus for transferring the heat so made available to the fluid being heated and vapourised."

#### Classification of Boilers :-

The boilers may be classified as follows :

##### 1. Horizontal, vertical or inclined

If the axis of the boiler is horizontal, the boiler is called as horizontal, if the axis is vertical, it is called vertical boiler and if the axis is inclined it is known as inclined boiler. The parts of a horizontal boiler can be inspected and repaired easily but it occupies more space. The vertical boiler occupies less floor area.

##### 2. Fire tube and water tube

In the fire tube boilers, the hot gases are inside the tubes and the water surrounds the tubes.

Examples :

*Cochran, Lancashire and Locomotive boilers.*

In the water tube boilers, the water is inside the tubes and hot gases surround them.

Examples : *Babcock and Wilcox, Stirling, Yarrow boiler etc.*

##### 3. Externally fired and internally fired

The boiler is known as externally fired if the fire is outside the shell. Examples : *Babcock and Wilcox boiler, Stirling boiler etc.*

In case of internally fired boilers, the furnace is located inside the boiler shell. Examples : *Cochran, Lancashire boiler* etc.

#### **4. Forced circulation and natural circulation**

In *forced circulation* type of boilers, the circulation of water is done by a *forced pump*.

Examples :

*Velox, Lamont, Benson boiler* etc.

In *natural circulation* type of boilers, circulation of water in the boiler takes place due to *natural convection* currents produced by the application of heat.

Examples :

*Lancashire, Babcock and Wilcox boiler* etc.

#### **5. High pressure and low pressure boilers**

The boilers which produce steam at *pressures of 80 bar and above* are called *high pressure* boilers.

Examples :

*Babcock and Wilcox, Velox, Lamont, Benson boilers*.

The boilers which produce steam at pressure *below 80 bar* are called *low pressure* boilers.

Examples :

*Cochran, Cornish, Lancashire and Locomotive boilers*.

#### **6. Stationary and portable**

Primarily, the boilers are classified as either stationary (*land*) or mobile (*marine* and *locomotive*).

Stationary boilers are used for power plant steam, for central station utility power plants, for plant process steam etc.

Mobile boilers or portable boilers include locomotive type, and other small units for temporary use at sites (just as in small coalfield pits).

#### **7. Single-tube and multi-tube boilers**

The fire tube boilers are classified as single-tube and multi-tube boilers, depending upon whether the fire tube is one or more than one. The examples of the former type are cornish, simple vertical boiler and rest of the boilers are multi-tube boilers.

## 4.2 Important terms of Boiler

**Shell :-** The shell of a boiler consists of one or more steel plates bent into a cylindrical form and riveted or welded together. The shell ends are closed with the end plates.

**Setting:-** The primary function of setting is to confine heat to the boiler and form a passage for gases. It is made of brickwork and may form the wall of the furnace and the combustion chamber. It also provides support in some types of boilers (*e.g.*, Lancashire boilers).

**Grate:-** It is the platform in the furnace upon which fuel is burnt and it is made of cast iron bars. The bars are so arranged that air may pass on to the fuel for combustion. The area of the grate on which the fire rests in a coal or wood fired boiler is called grate surface.

**Furnace:-** It is a chamber formed by the space above the grate and below the boiler shell, in which combustion takes place. It is also called a fire box.

**Water space and steam space :-** The volume of the shell that is occupied by the water is termed *water space* while the entire shell volume less the water and tubes (if any) space is called *steam space*.

**Mountings:-** The items such as stop valve, safety valves, water level gauges, fusible plug, blow-off cock, pressure gauges, water level indicator etc. are termed as mountings and a *boiler cannot work safely without them*.

**Accessories:-** The items such as superheaters, economisers, feed pumps etc. are termed as accessories and they form integral part of the boiler. They *increase the efficiency of the boiler*.

**Water level :-**The level at which water stands in the boiler is called *water level*. The space above the water level is called *steam space*.

**Foaming :-**Formation of steam bubbles on the surface of boiler water due to high surface tension of the water.

**Scale :-**A deposit of medium to extreme hardness occurring on water heating surfaces of a boiler because of an undesirable condition in the boiler water.

**Blowing off :-**The removal of the mud and other impurities of water from the lowest part of the boiler (where they usually settle) is termed as '*blowing off*'. This is accomplished with the help of a blow off cock or valve.

**Lagging:-** Blocks of asbestos or magnesia insulation wrapped on the outside of a boiler shell or steam piping.

**Refractory:-** A heat insulation material, such as fire brick or plastic fire clay, used for such purposes as lining combustion chambers.

### 4.3 Comparison between Fire-tube and Water-tube Boilers

S.L No.	Particulars	Fire-tube boilers	Water-tube boilers
1	Position of water and hot gases	Hot gases inside the tubes and water outside the tubes.	Water inside the tubes and hot gases outside the tubes.
2	Mode of firing	Internally fired.	Externally fired.
3	Operating pressure	Operating pressure limited to 16 bar	Can work under as high Pressure as 100 bar
4	Rate of steam production	Lower	Higher
5	<i>Suitability</i>	Not suitable for large power plants	Suitable for large power plants

## 4.4 Description & Working of Common boilers (Cochran ,Lancashire ,Babcock & Wilcox Boiler )

### Cochran Boiler :-

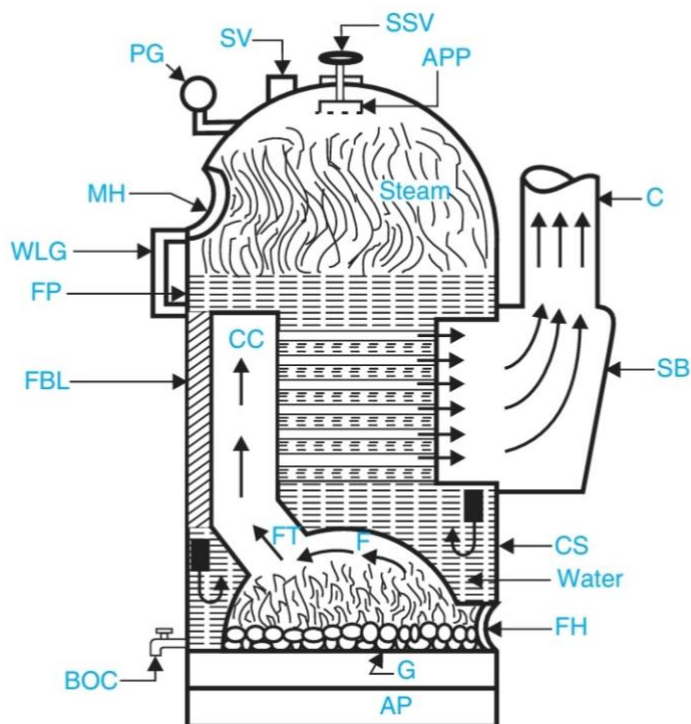

CS = Cylindrical shell	FT = Flue tube
CC = Combustion chamber	SB = Smoke box
FBL = Fir brick lining	C = Chimney
F = Furnace (dome shaped)	FH = Fire hole
G = Grate	BOC = Blow-off cock
AP = Ash pit	SSV = Steam stop valve
SV = Safety valve	APP = Antipriming pipe
MH = Man hole	PG = Pressure gauge
WLG = Water level gauge	

### Cochran Boiler

- It is *one of the best* types of vertical multi-tubular boiler, and has a number of horizontal fire tubes.

- Cochran boiler consists of a cylindrical shell with a dome shaped top where the space is provided for steam.
- The furnace is one piece construction and is seamless.
- Its crown has a hemispherical shape and thus provides maximum volume of space. The fuel is burnt on the grate and ash is collected and disposed of from ash pit.
- The gases of combustion produced by burning of fuel enter the combustion chamber through the flue tube and strike against fire brick lining which directs them to pass through number of horizontal tubes, being surrounded by water.
- After which the gases escape to the atmosphere through smoke box and chimney.
- A number of hand-holes are provided around the outer shell for cleaning purposes.

The various boiler mountings shown in Fig. above are :

- (i) Water level gauge
- (ii) Safety valve,
- (iii) Steam stop valve,
- (iv) Blow off cock,
- (v) Manhole, and
- (vi) Pressure gauge.

The path of combustion of gases and circulation of water are shown by arrows in above fig ..

### Lancashire boiler :-

- This boiler is *reliable*, has *simplicity of design*, *ease of operation* and *less operating and maintenance costs*.
- It is commonly used in *sugar-mills* and *textile industries* where along with the power steam and steam for the process work is also needed.
- In addition this boiler is used where larger reserve of water and steam are needed.

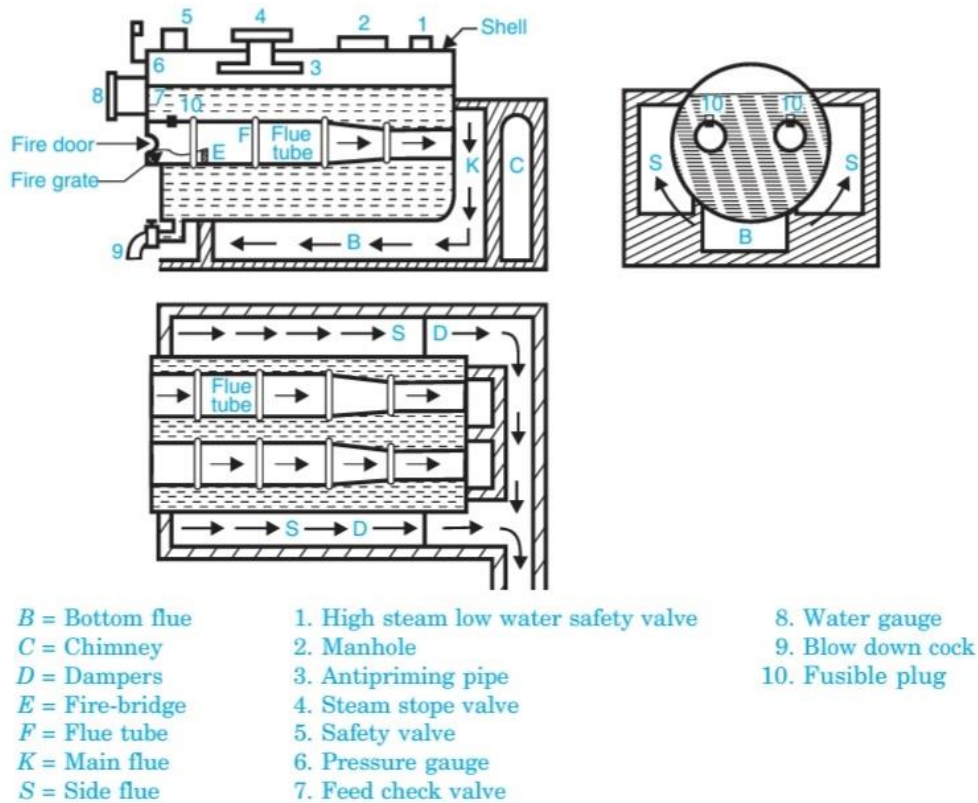

## Lancashire boiler

- The Lancashire boiler consists of a cylindrical shell inside which two large tubes are placed.
- The shell is constructed with several *rings* of cylindrical form and it is placed horizontally over a brick work which forms several channels for the flow of hot gases.
- These two tubes are also constructed with several rings of cylindrical form.
- They pass from one end of the shell to the other and are covered with water.
- The furnace is placed at the front end of each tube and they are known as furnace tubes.
- The coal is introduced through the fire hole into the grate.
- There is low brickwork fire bridge at the back of the grate to prevent the entry of the burning coal and ashes into the interior of the furnace tubes.



- The combustion products from the grate pass up to the back end of the furnace tubes and then in downward direction. Thereafter they move through the bottom channel or bottom flue up to the front end of the boiler where they are divided and pass up to the side flues.
- Now they move along the two side flues and come to the chimney flue from where they lead to the chimney.
- To control the flow of hot gases to the chimney, dampers (in the form of sliding doors) are provided.
- As a result the flow of air to the grate can be controlled. The various mountings used on the boiler are shown in above Fig.

### Babcock and wilcox water tube boiler :-

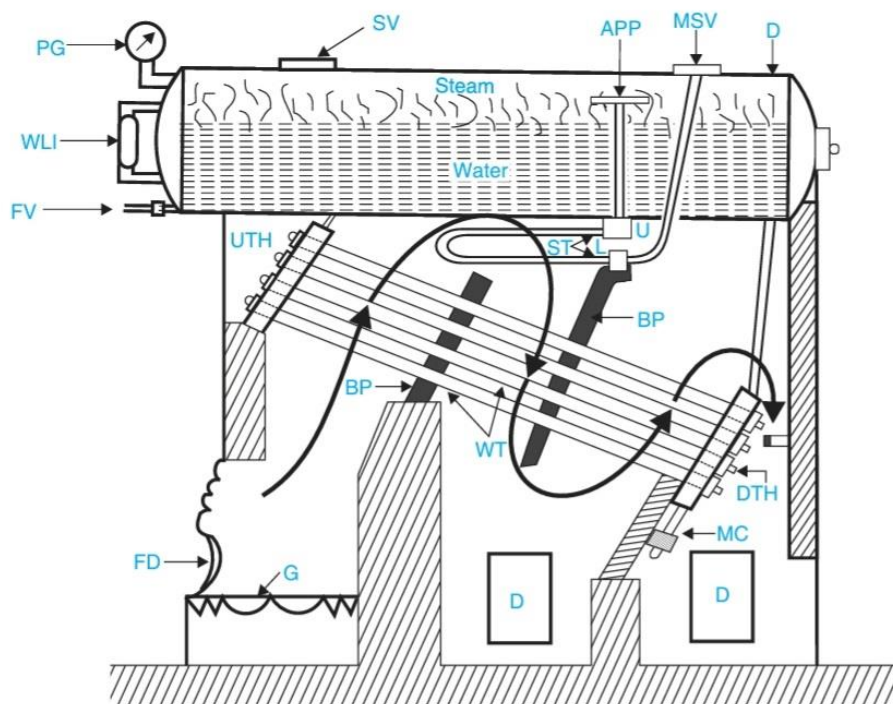

- |                                    |                               |
|------------------------------------|-------------------------------|
| <i>D</i> = Drum                    | <i>PG</i> = Pressure gauge    |
| <i>DTH</i> = Down take header      | <i>ST</i> = Superheater tubes |
| <i>WT</i> = Water tubes            | <i>SV</i> = Safety valve      |
| <i>BP</i> = Baffle plates          | <i>MSV</i> = Main stop valve  |
| <i>D</i> = Doors                   | <i>APP</i> = Antipriming pipe |
| <i>G</i> = Grate                   | <i>L</i> = Lower junction box |
| <i>FD</i> = Fire door              | <i>U</i> = Upper junction box |
| <i>MC</i> = Mud collector          | <i>FV</i> = Feed valve.       |
| <i>WLI</i> = Water level indicator |                               |

Babcock and wilcox water tube boiler

- The water tube boilers are used exclusively, when pressure above 10 bar and capacity in excess of 7000 kg of steam per hour is required.
- Babcock and Wilcox water tube boiler is an example of horizontal straight tube boiler and may be designed for stationary or marine purposes.
- Fig. above shows a Babcock and Wilcox boiler with longitudinal drum.
- It consists of a drum connected to a series of front end and rear end headers by short riser tubes.
- To these headers are connected a series of inclined water tubes of solid drawn mild steel.
- The angle of inclination of the water tubes to the horizontal is about 15° or more.
- A hand hole is provided in the header in front of each tube for cleaning and inspection of tubes.
- A feed valve is provided to fill the drum and inclined tubes with water the level of which is indicated by the water level indicator.
- Through the fire door the fuel is supplied to grate where it is burnt.
- The hot gases are forced to move upwards between the tubes by baffle plates provided.
- The water from the drum flows through the inclined tubes *via* down take header and goes back into the shell in the form of water and steam *via* uptake header.
- The steam gets collected in the steam space of the drum.
- The steam then enters through the anti priming pipe and flows in the superheater tubes where it is further heated and is finally taken out through the main stop valve and supplied to the engine when needed.

- At the lowest point of the boiler is provided a mud collector to remove the mud particles through a blow-down cock.
- The entire boiler except the furnace are hung by means of metallic slings or straps or wrought iron girders supported on pillars.
- This arrangement enables the drum and the tubes to expand or contract freely.
- The brickwork around the boiler encloses the furnace and the hot gases.
- The various mountings used on the boiler are shown in above Fig.
- A Babcock Wilcox water tube boiler with cross drum differs from longitudinal drum boiler in a way that how drum is placed with reference to the axis of the water tubes of the boiler.
- The longitudinal drum restricts number of tubes that can be connected to one drum circumferentially and limits the capacity of the boiler.
- In the cross drum there is no limitation of the number of connecting tubes. The pressure of steam in case of cross drum boiler may be as high as 100 bar and steaming capacity upto 27,000 kg/h.

#### **4.5 Boiler Draught :-**

**Boiler Draught:-** The boiler draught may be defined as the small pressure difference which causes the continuous flow of gases inside the boiler. In other words, the draught is a small pressure difference between the air outside the boiler and gases within the furnace or chimney.

## Function of Draught :-

- It forces a sufficient quantity of air into the furnace for proper combustion of fuel.
- It circulates the hot flue gases through the flue tubes, superheater, economiser, air preheater etc.
- It discharges the hot flue gases to the atmosphere through the chimney.

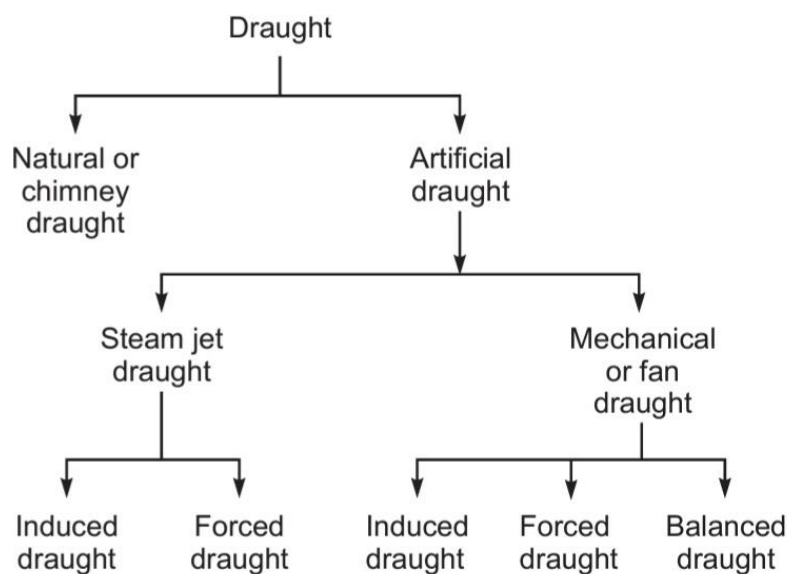

**Draught produced by a fan or blower may be of three types: (a) induced, (b) forced, and (c) balanced draught.**

## Induced draught :-

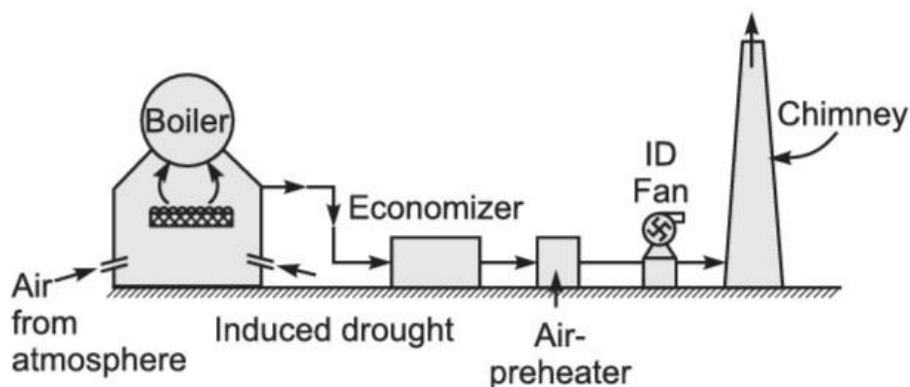

- The fan is placed near the base of the chimney as shown in Fig. above
- The fan draws the flue gases from the furnace. So the pressure above the fuel bed is reduced below the atmospheric pressure.
- The fresh air rushes to the furnace and after combustion, the flue gases get discharged through the chimney in the atmosphere..

### Forced Draught :-

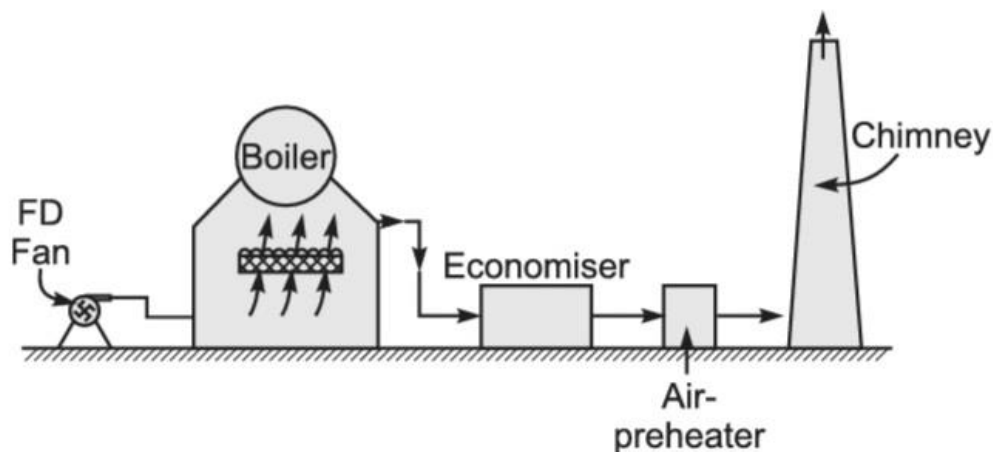

- The fan or blower is located near or at the base of the boiler grate to force atmospheric air on to the furnace under pressure.
- This pressure helps in circulation of flue gases through components of the boiler and then through chimney to atmosphere. It is shown in above Fig.

### Balanced draught :-

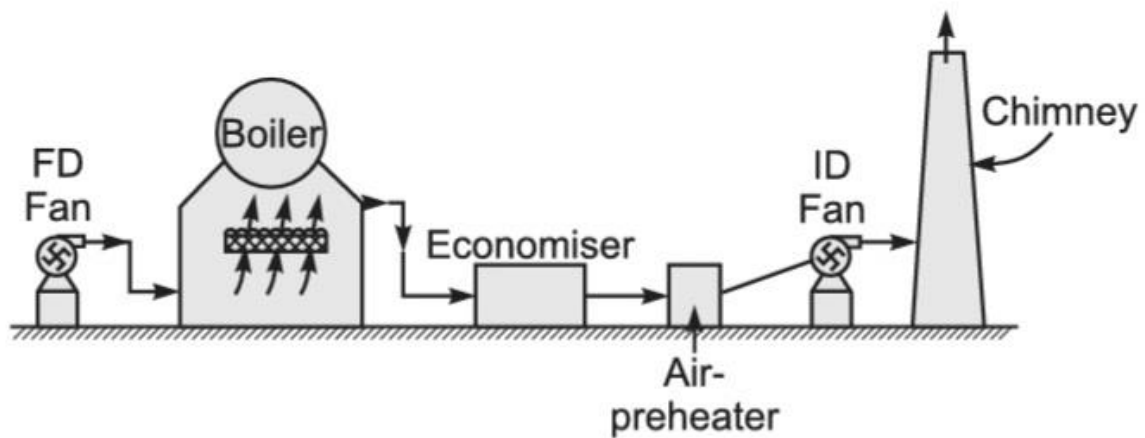

- A combination of induced and forced draught in a boiler is known as a balanced draught.
- A forced draught fan located near the grate supplies air under the pressure through the furnace and an induced draught fan located near the chimney base, draws in flue gases through the economiser, air preheater, etc., and discharges them into the atmosphere through a chimney.
- Figure above illustrates the balanced draught system.

### 4.6 Boiler mounting & Accessories:-

The boiler mountings are the different fittings and devices which are mounted on a boiler shell for proper functioning and safety.

These form an integral part of the boiler.

These are in two groups:

(a) **Mountings for Safety :-**

1. Safety valve
2. Water-level indicator
3. Fusible plug

(b) **Mountings for Control :-**

4. Pressure gauge
5. Steam stop valve
6. Feed check valve
7. Blow off cock

**Safety valve :-**

- Safety valves are located on the top of the boiler.
- They guard the boiler against the excessive high pressure of steam inside the drum.
- If the pressure of steam in the boiler drum exceeds the working pressure then the safety valve allows to blow-off a certain quantity of steam to the atmosphere, and thus the pressure of steam falls in the drum.
- The escape of steam makes an audible noise as alarm to warn the boiler attendant.

There are four types of safety valves.

1. Dead-weight safety valve
2. Spring-loaded safety valve
3. Level-loaded safety valve
4. High steam and low water safety valve

**1. Dead-weight safety valve:-**

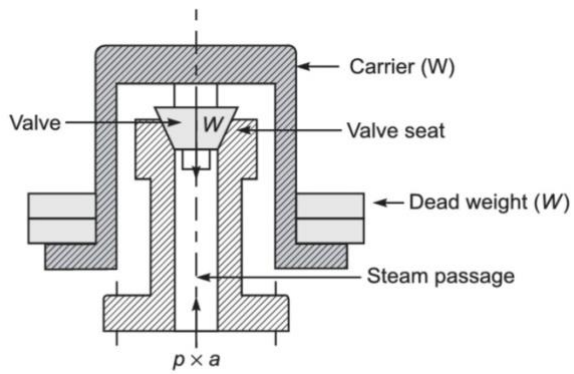

## 2. Spring-loaded safety valve:-

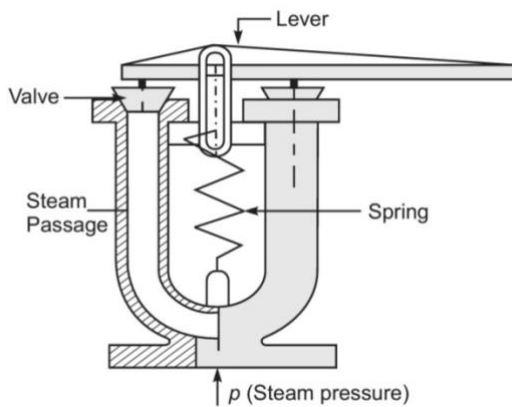

## 3. Level-loaded safety valve:-

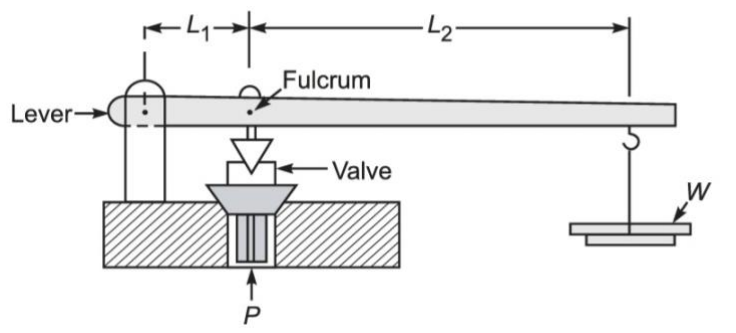

## 4. High steam and low water safety valve :-



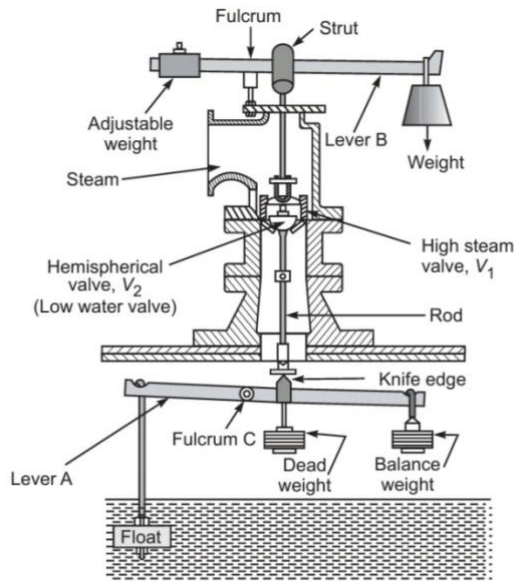

## Water-level indicator :-

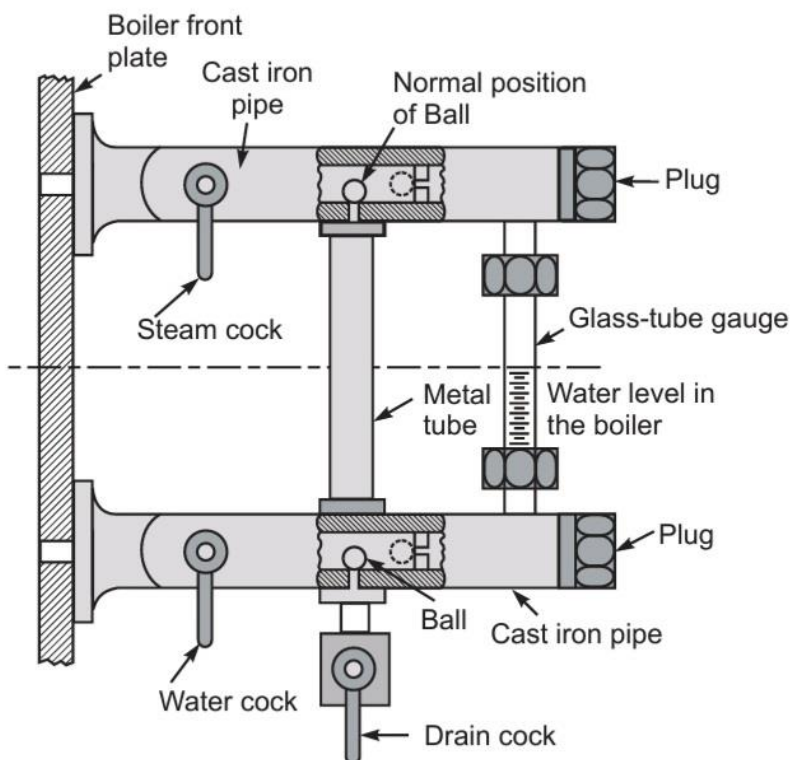

- The water level indicator is located in front of the boiler in such a position that the level of water can easily be seen by the attendant. Two water-level indicators are used on all boilers.

- During the boiler operation, the steam cock and water cock remain opened while the drain cock is kept closed. During the normal operation, the two balls provided inside the gunmetal pipe remain in position as shown in above Fig. .
- Hence, the water can reach the glass gauge and its level can be seen.
- In case the glass gauge breaks accidentally, the water and steam simultaneously rush out through the gunmetal pipes. The force is exerted on two balls and they are carried away by water and steam and the passages are closed.
- The water and steam cocks are then closed and the glass gauge is replaced.

### Fusible plug :-

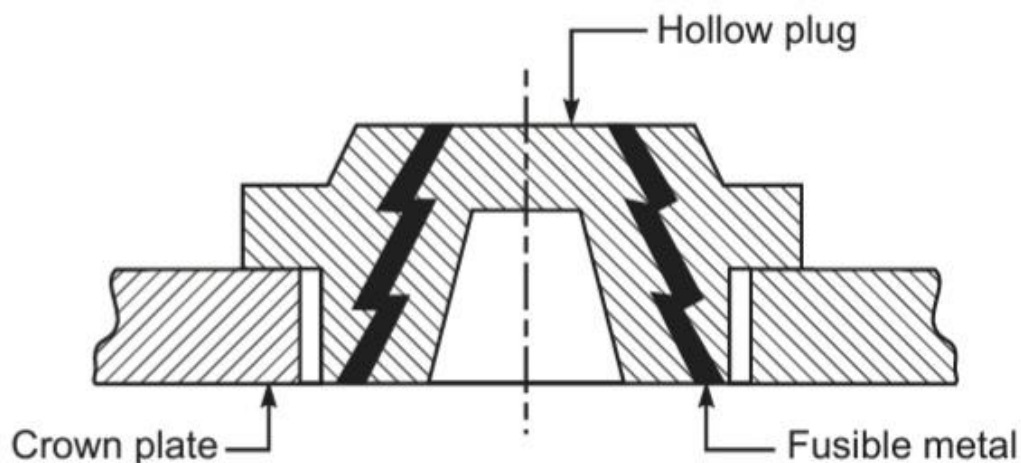

- It is a very important safety device which protects the fire-tube boiler shell against overheating.
- It is located just above the furnace in the boiler. It consists of a gunmetal plug fixed in a gunmetal body with a fusible molten metal as shown in above Fig.

- During the normal boiler operation, the fusible plug is covered by water and its temperature does not rise to its melting state. But when the water level falls too low in the boiler, it uncovers the fusible plug.
- The furnace gases heat up the plug, the fusible metal of the plug melts, and the inner plug falls down. The water and steam then rush through the hole and extinguish the fire before any major damage occurs to the boiler due to overheating

### Pressure gauge :-

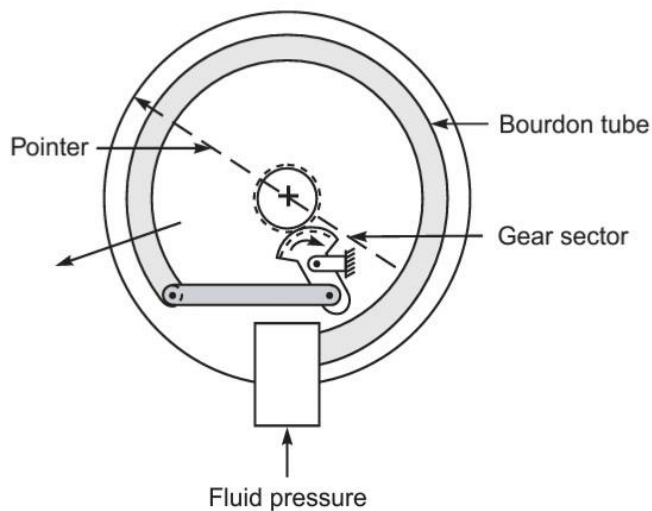

(a) Bourdon pressure gauge

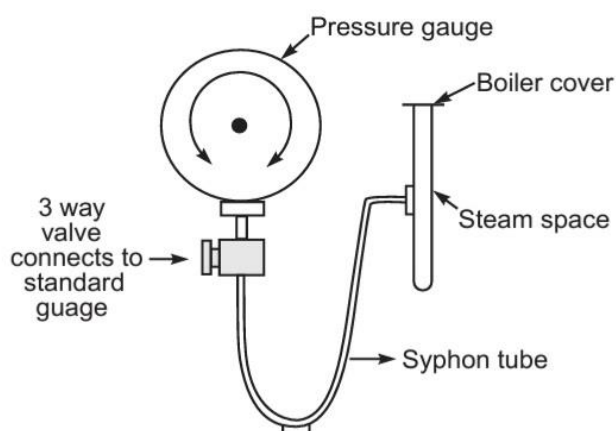

(b) Pressure gauge with syphon tube

- A pressure gauge is fitted in front of the boiler in such a position that the operator can conveniently read it. It reads the pressure of steam in the boiler and is connected to the steam space by a siphon tube.
- The most commonly used gauge is the Bourdon pressure gauge. Figure (a) illustrates the Bourdon pressure gauge. It consists of an elliptical spring Bourdon tube. One end of this tube is connected to the siphon tube and other end is connected by levers and gears to pointer. When fluid pressure acts on the Bourdon tube, it tries to make its cross-section change from elliptical to circular. In this process, the lever end of the tube moves out as indicated by an arrow.
- The tube movement is magnified by the mechanism and given to pointer to move over a circular scale indicating the pressure.
- The siphon tube, is shown in Fig. (b), it connects the steam space of the boiler to the Bourdon gauge is filled with water in order to avoid the effect of high temperature steam on the gauge components. The steam pressure is transferred by water to the Bourdon pressure gauge

### **Steam stop valve :-**

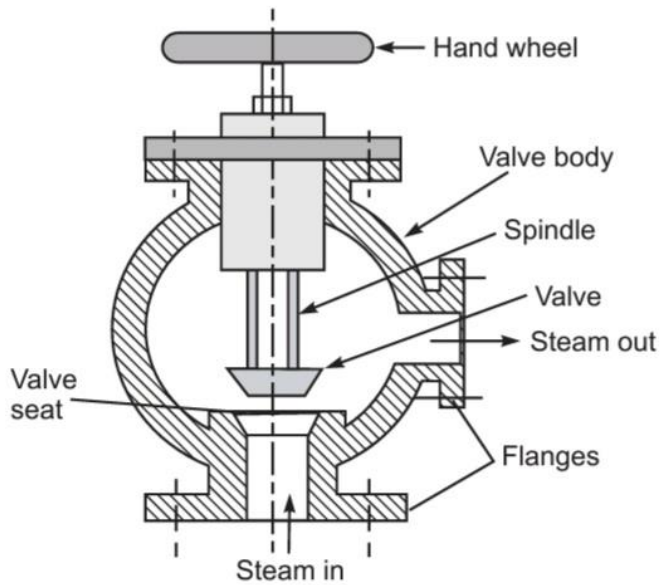

The steam stop valve is located on the highest part of the steam space. It regulates the steam supply for use. The steam stop valve can be operated manually or automatically.

### Feed check valve :-

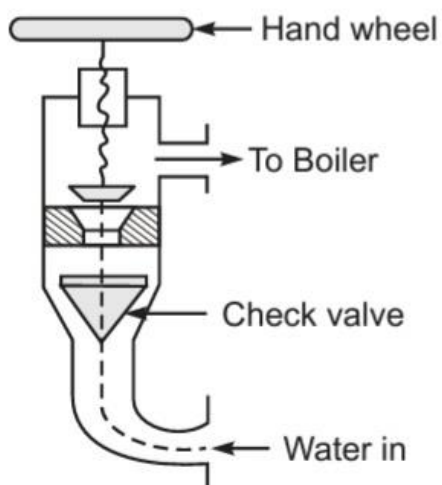

The feed check valve is fitted to the boiler, slightly below the working level in the boiler. It is used to supply high-pressure feed water to the boiler. It also prevents the returning of feed water from the boiler if the feed pump fails to work.

### Blow off cock :-

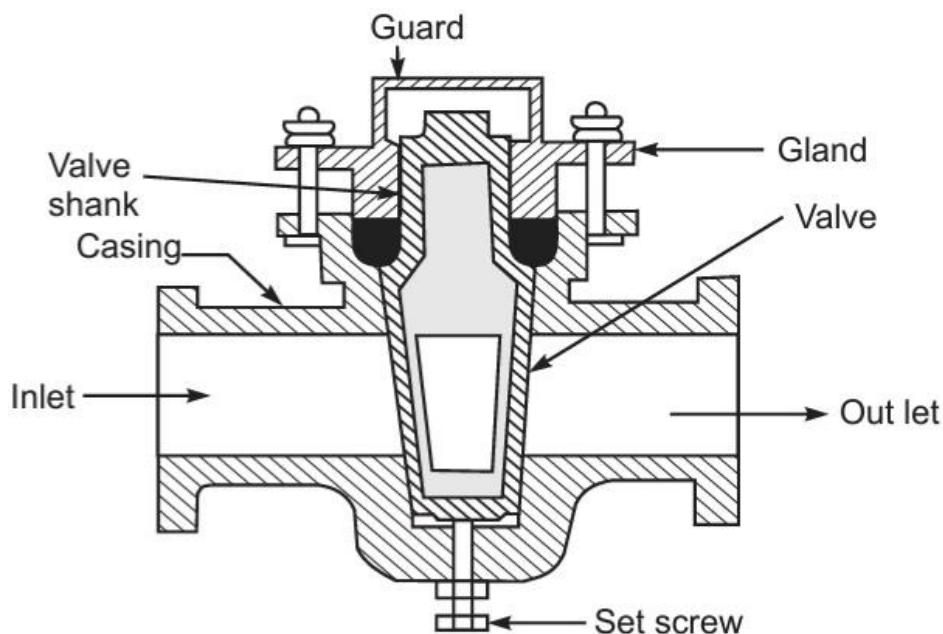

The function of the blow-off cock is to discharge mud and other sediments deposited in the bottommost part of the water space in the boiler, while the boiler is in operation. It can also be used to drain off the boiler water. Hence it is mounted at the lowest part of the boiler. When it is open, water under the pressure rushes out, thus carrying sediments and mud.

### Boiler Accessories:-

The accessories are mounted on the boiler to increase its efficiency. These units are optional on an efficient boiler. The following accessories are normally used on a modern boiler:

(i) Superheater

- (ii) Economiser
- (iii) Air preheater
- (iv) Feed-water pump
- (v) Steam injector
- (vi) Steam separator
- (vii) Steam trap

### Superheater :-

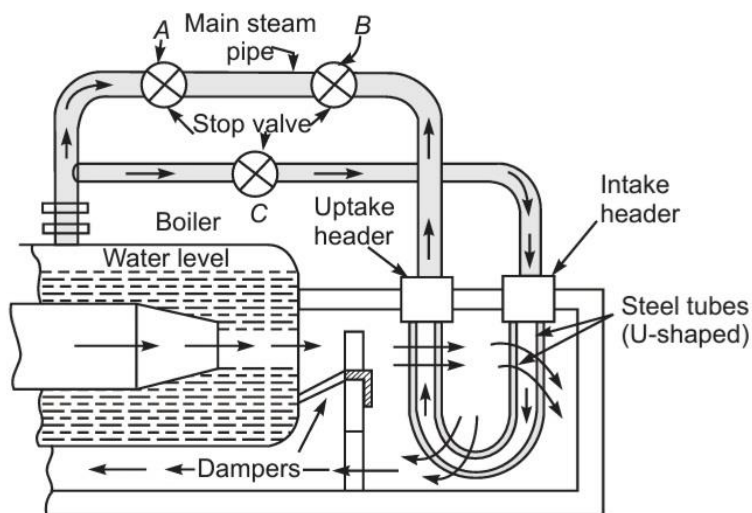

It is a heat exchanger in which products of heat of combustion are utilized to dry the wet steam and to make it superheated by increasing its temperature. During superheating of the steam, pressure remains constant, and its volume and temperature increase. A super-heater consists of a set of small-diameter U tubes in which steam flows and takes up the heat from hot flue gases.

### Economiser :-

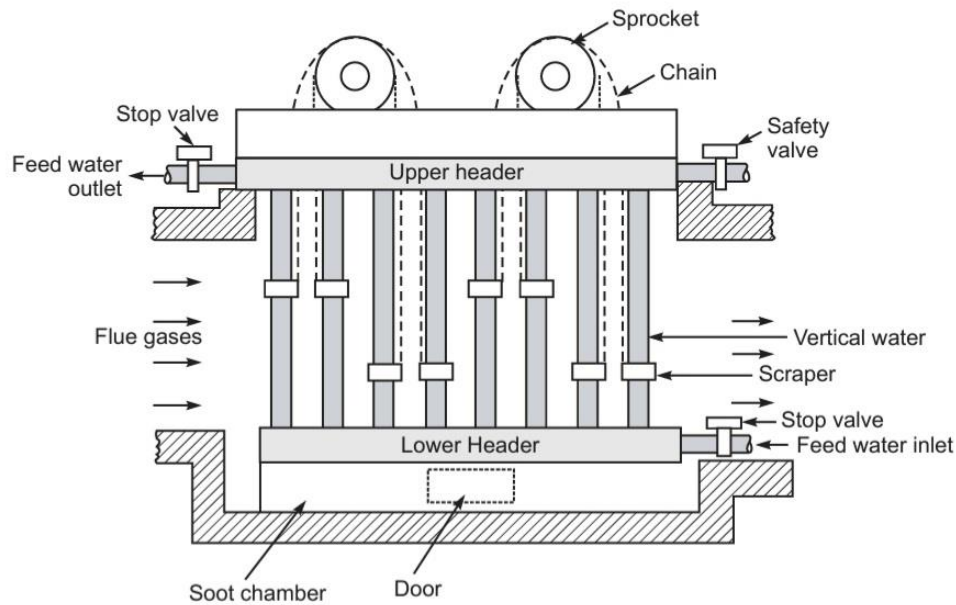

An economiser is a heat exchanger used for heating the feed water before it enters the boiler. The economiser recovers some of waste heat of hot flue gases going to the chimney thus it helps in improving the boiler efficiency. It is placed in the path of flue gases at the rear end of the boiler just before the air preheater. The most popular economiser is Green's economiser and it is shown in Fig.

### Air preheater:-

The function of an air preheater is similar to that of an economiser. It recovers some portion of the waste heat of hot flue gases going to the chimney, and transfers the same to the fresh air before it enters the combustion chamber. A tubular air preheater is shown in Fig. below



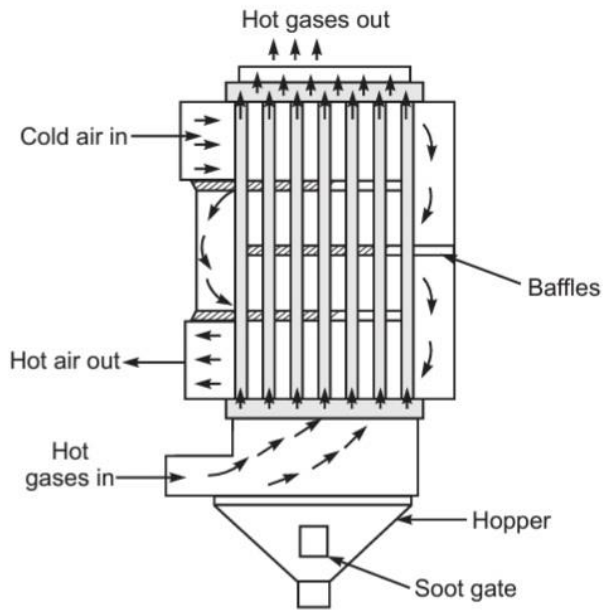

### Feed-water pump:-

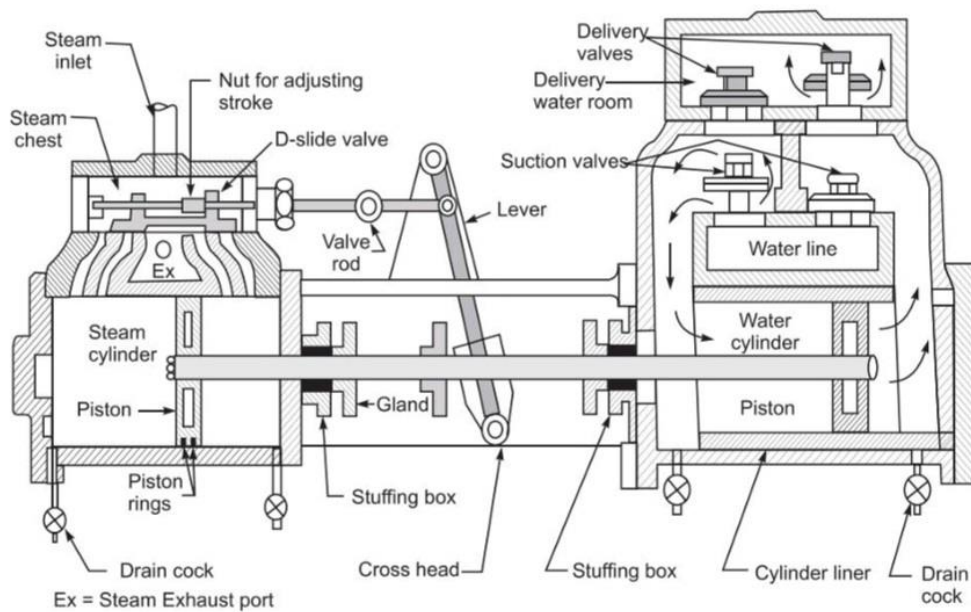

The feed pump delivers feed water at a pressure higher than that in the boiler.

### Steam injector :-

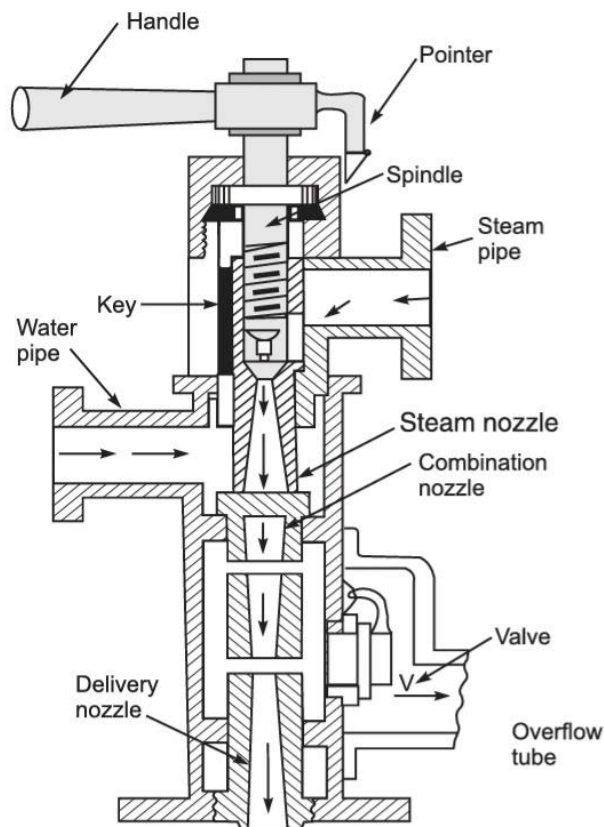

A steam injector lifts and forces the feed water into the boiler. It is usually used for vertical and locomotive boilers and can be accommodated in a small space. It is less costly and does not have any moving parts. Thus, operation is silent.

### Steam separator:-

A steam separator is installed on the steam main as well as on the branch lines to separate any water particles present from the steam and to improve the quality of the steam going to the units. It is installed very close to units on main steam pipes. By change of direction of steam, steam separators cause the condensed water particles to be separated out and delivered to a point where they can

A few types of separators are illustrated in Fig. bellow

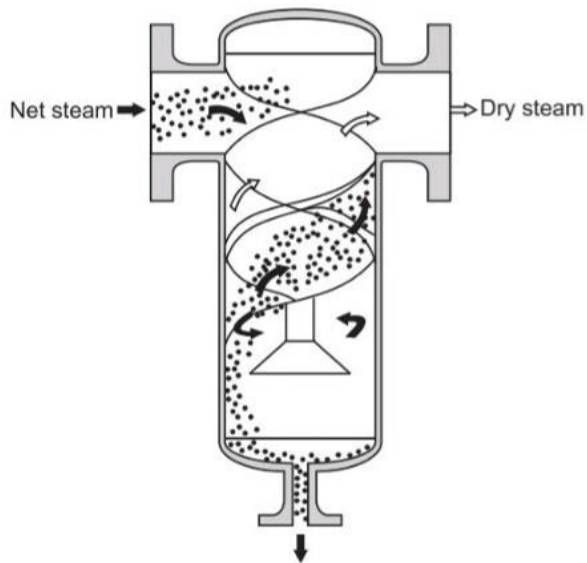

A cyclonic-type separator

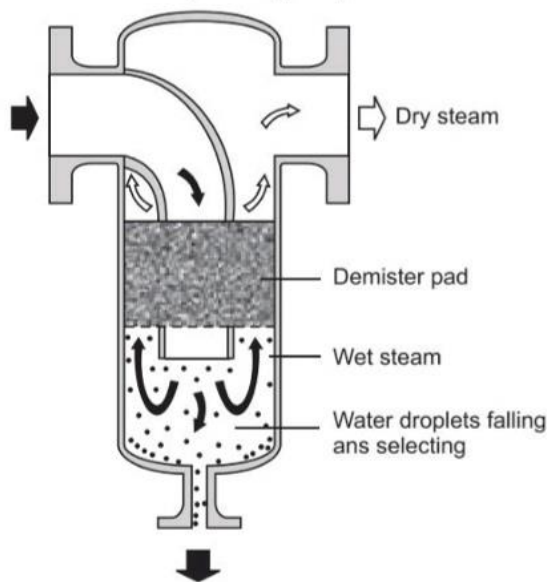

A Coalescence-type separator

### Steam trap:-

A steam trap is a valve device that drains away the condensed steam and air automatically from the steam pipe, steam jackets or steam separator without discharging the steam. The purpose of installing the steam traps in the process equipment is to obtain fast heating of the product and equipment by keeping the steam lines and equipment free of condensate, air and non-condensable gases.

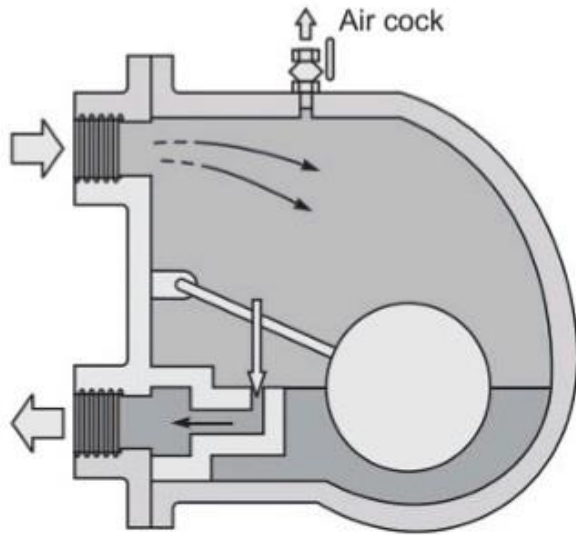

Steam trap

## QNA CH.4

### Short Question

**Q. What is boiler ?**

**Ans:-**

In simple a **boiler** may be defined as a closed vessel in which steam is produced from water by combustion of fuel.

**Q. Define Fire tube and water tube ?**

**Ans:-**

#### Fire tube

In the fire tube boilers, the hot gases are inside the tubes and the water surrounds the tubes.

Examples :

*Cochran, Lancashire and Locomotive boilers.*

#### Water tube

In the water tube boilers, the water is inside the tubes and hot gases surround them.

Examples : *Babcock and Wilcox, Stirling, Yarrow boiler etc.*

**Q.3 Define Single-tube and multi-tube boilers ?**

**Ans:-**

The fire tube boilers are classified as single-tube and multi-tube boilers, depending upon whether the fire tube is one or more than one. The examples of the former type are cornish, simple vertical boiler and rest of the boilers are multi-tube boilers.

**Q.4 What is Grate ?**

**Ans:-**

It is the platform in the furnace upon which fuel is burnt and it is made of cast iron bars. The bars are so arranged that air may pass on to the fuel for combustion. The area of the grate on which the fire rests in a coal or wood fired boiler is called grate surface.

Q.5 Define Superheater ?

**Ans:-**

It is a heat exchanger in which products of heat of combustion are utilized to dry the wet steam and to make it superheated by increasing its temperature. During superheating of the steam, pressure remains constant, and its volume and temperature increase. A super-heater consists of a set of small-diameter U tubes in which steam flows and takes up the heat from hot flue gases.

### **Long question**

**Q .1 Description & Working of Cochran Wilcox Boiler ?**

**Ans:- See Article 4.4**

**Q.2 Description & Working of Lancashire Boiler ?**

**Ans:- :- See Article 4.4**

**Q.3 Short notes on Boiler Draught ?**

**Ans:- :- See Article 4.5**

**Q.4 Short notes on Boiler mounting & Accessories ?**

**Ans:- :- See Article 4.6**

## CHAPTER 5

### Steam Power Cycle

#### 5.1 Carnot cycle with vapour

- When we think of a power cycle of maximum efficiency, the Carnot cycle immediately conjures up in our mind.
- It is a cycle, which has maximum efficiency, operating between given temperature limits and its efficiency is independent of properties of working fluid.
- A Carnot vapour power cycle is executed within saturation dome of a pure substance. It uses a two phase fluid as the working medium as shown in fig.

Figure (a) gives the arrangement of components in the cycle, (b) shows Carnot vapour power cycle on  $p$ - $v$  coordinates, (c) on  $T$ - $s$  coordinates, and (d) on  $h$ - $s$  coordinates.

The boundary of the region in which liquid and vapour are both present (the vapour dome) is also indicated.

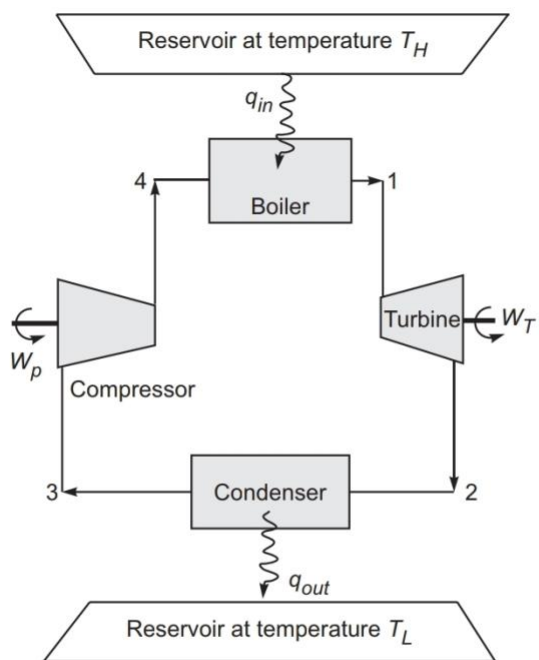

(a) Schematic

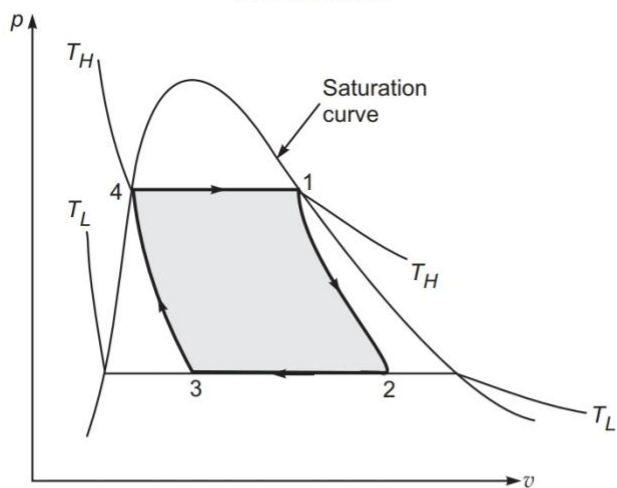

(b)  $p$ - $v$  as diagram

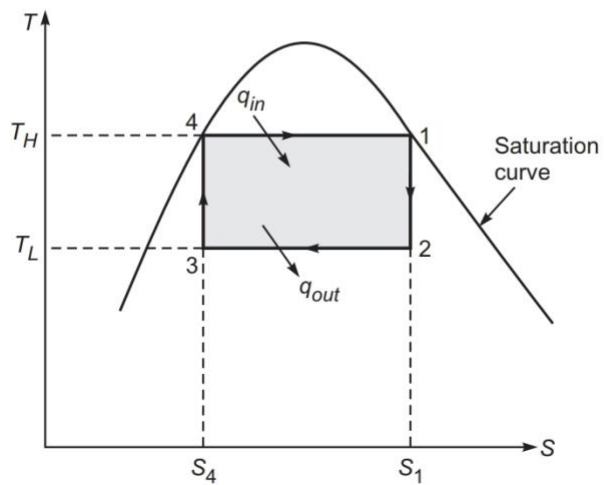

(c)  $T$ - $s$  diagram



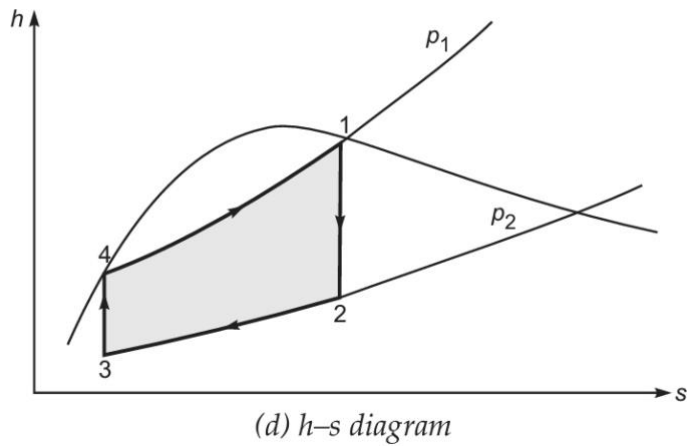

Figure (a) gives the arrangement of components in the cycle ,  
 Figure (b) shows carnot vapour power cycle on  $p-v$  coordinates ,  
 Figure (c) on  $T-s$  coordinates .

The four processes in the cycle are as follows :-

### **1.Reversible Adiabatic Expansion 1-2**

Saturated steam expands in the turbine . The temperature lowers from  $T_H$  to  $T_L$ .The state 2 is reached in the wet region .

### **2.Controlled Condensation 2-3**

During this process ,the condensation starts from state 2 and stops at state 3 and the heat  $q_L$  per unit mass is rejected in the condenser to the sink at  $T_L$ .

### **3.Reversible Adiabatic compression3-4**

The mixture of liquid and vapour is compressed to the saturation liquid state 4 at boiler pressure .

### **4.Reversible Isothermal heat addition 4-1**

During this process , a quantity of heat  $q_H$  per unit mass is added in the boiler from heat source at the temperature  $T_H$ .

## **5.2 Derive work & efficiency of the cycle**

Isothermal heat addition to a vapourising fluid in the boiler;

$$Q_{in} = T_H (s_1 - s_4)$$

Isothermal heat rejected by the working substance in the condenser;

$$Q_{out} = T_L (s_1 - s_4)$$

The net work done of the cycle;

$$\begin{aligned} W_{net} &= q_{in} - q_{out} \\ &= T_H (s_1 - s_4) - T_L (s_1 - s_4) \\ &= (T_H - T_L)(s_1 - s_4) \end{aligned}$$

The thermal efficiency of the cycle;

$$\begin{aligned} \eta_{Carnot} &= \frac{w_{net}}{q_{in}} = \frac{(T_H - T_L)(s_1 - s_4)}{T_H (s_1 - s_4)} \\ &= 1 - \frac{T_L}{T_H} \end{aligned}$$

---



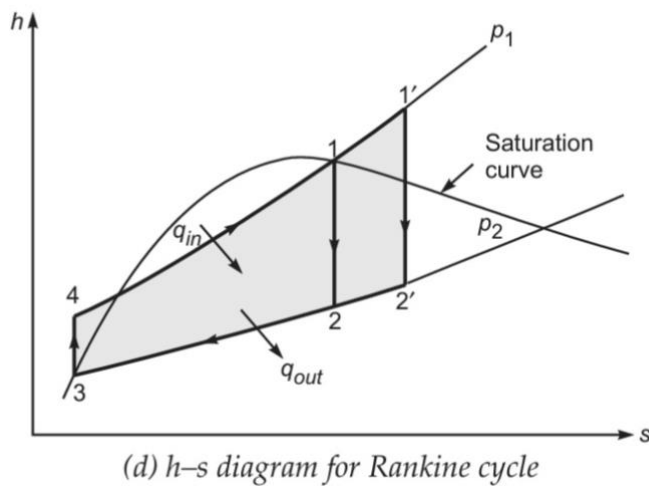
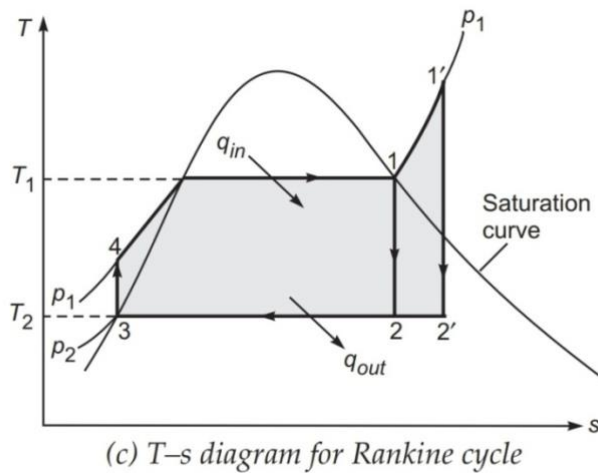

**Process 1-2** :- Isentropic expansion of the working fluid in turbine from boiler pressure to condenser pressure .

**Process 2-3** :- Heat rejection from the working fluid at constant pressure in the condenser till the fluid reaches the saturated liquid state 3 .

**Process 3-4** :- Isentropic compression of the working fluid in the pump to the boiler pressure at the state 4 in the compressed liquid region .

**Process 4-1:-** Heat addition to working fluid at constant pressure in the boiler from state 4 to 1.

### **5.3.2 Derive work & efficiency of the cycle**

We assume 1 kg of working substance in the cycle and applying steady flow energy equation to each component in the cycle. If changes of kinetic and potential energy are neglected then the steady-flow energy equation reduces to

$$q - w = \Delta h$$

- (i) For isentropic compression ( $q = 0$ ) in the pump (process 3–4);

$$w_p = h_4 - h_3$$

Taking pump work negative; then

$$w_p = h_4 - h_3$$

where  $h_3$  is hf enthalpy of liquid at condenser pressure  $p_2$ .

$h_4$  is the enthalpy of water at state 4, calculated as

$$h_4 = h_3 + w_p$$

Then the isentropic compression work  $w_p$  is obtained as

$$w_p = \int_{p_2}^{p_1} v dp = v(p_1 - p_2) .$$

where  $v_f$  is the specific volume of liquid at condenser pressure  $p_2$

- (ii) For constant-pressure heat addition process in the boiler ( $w = 0$ ):

$$q_{2-3} = q_{in} = h_1 - h_4$$

- (iii) For isentropic expansion process 1–2 in the turbine ( $q = 0$ ):

$$w_T = h_2 - h_1$$

$$\text{or } w_T = h_1 - h_2$$

- (iv) For isentropic expansion process 1–2 in the turbine ( $q = 0$ ):

$$w_T = h_2 - h_1$$

$$\text{or } w_T = h_1 - h_2$$

(iv) For constant-pressure heat removal process 2-3 in the condenser ( $w = 0$ ):

$$q_{2-3} = q_{out} = h_3 - h_2$$

Taking negative sign for heat rejection, then

$$q_{out} = h_2 - h_3 .$$

The thermal efficiency of any power cycle is expressed as

$$\eta = \frac{\text{Net work done in the cycle}}{\text{Heat supplied in the cycle}} = \frac{w_{net}}{q_{in}}$$

For Rankine cycle,

$$\begin{aligned} w_{net} &= w_T - w_p \\ &= (h_1 - h_2) - v_f (p_1 - p_2) \end{aligned}$$

For a thermodynamic cycle, the net work is also equal to net heat transfer;

$$\begin{aligned} w_{net} &= q_{in} - q_{out} \\ &= (h_1 - h_4) - (h_2 - h_3) \end{aligned}$$

Efficiency of Rankine cycle can be expressed as :

$$\begin{aligned} \eta_{Rankine} &= \frac{q_{in} - q_{out}}{q_{in}} = 1 - \frac{q_{out}}{q_{in}} \\ &= 1 - \frac{h_2 - h_3}{h_1 - h_4} . \end{aligned}$$

---

### 5.3.3 Effect of Various end conditions in Rankine Cycle :-

➤ By Increase in Boiler pressure :-

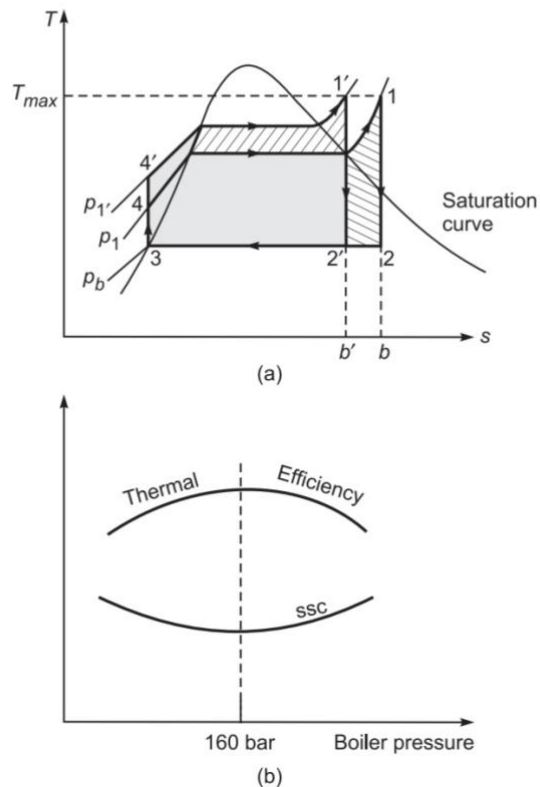

By increasing the boiler pressure, the mean temperature of heat addition increases, and thus raises the thermal efficiency of the cycle. Fig. (a) illustrates the effect of boiler pressure on Rankine cycle efficiency.

Effect due to Increase in Boiler pressure:-

- 1) Turbine work ( $W_T$ ) increase
- 2) Pump work ( $W_P$ ) increase
- 3) Net Work =  $W_T - W_P$  increase
- 4) Efficiency increase
- 5) Heat rejection ( $Q_R$ ) decrease
- 6) Heat addition ( $Q_S$ ) cannot say

➤ **Super heating :-**

Superheating of steam increases the mean temperature of heat addition . The effect of superheated steam on performance of the Rankine cycle is shown in below fig.

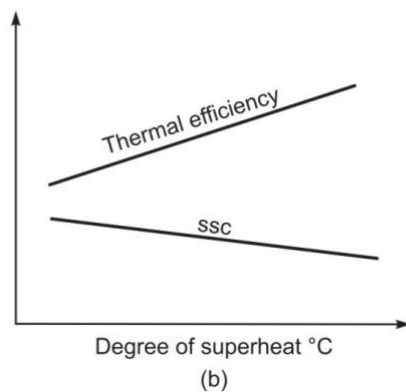
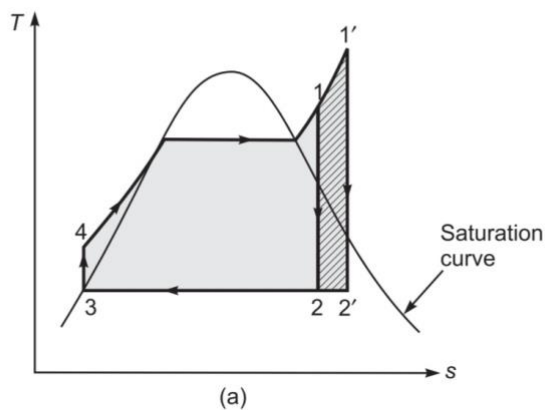

**Effect of superheating :-**

- 1) Turbine work ( $W_T$ ) increase
- 2) Pump work ( $W_P$ ) remain constant
- 3) Net Work =  $W_T - W_P$  increase
- 4) Efficiency increase
- 5) Heat rejection ( $Q_R$ ) increases
- 6) Heat addition ( $Q_S$ ) increases



**5.3.4 Reheating of Cycle:-** In this process heat is added to the steam .The reheated steam then further expands in the next stage of the turbine .Due to reheating , the work output of the turbine increases ,thus improving the thermal efficiency .

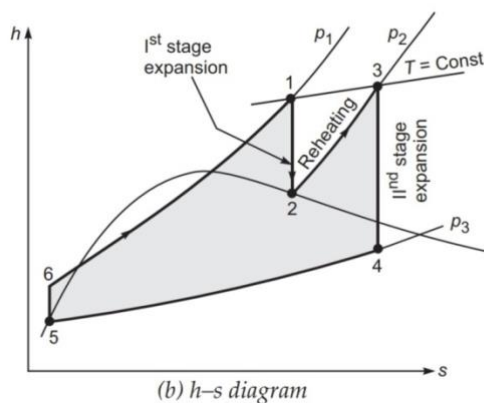
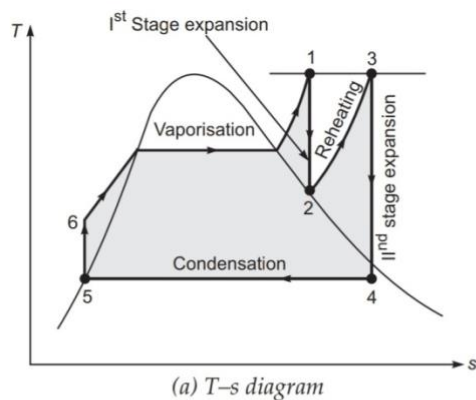
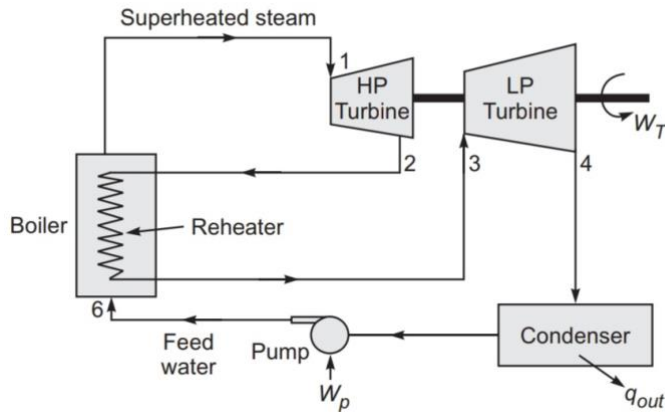

**Effect of Reheating of steam :-**

- 1) Turbine work ( $W_T$ ) =  $(h_1 - h_2) + (h_3 - h_4)$  increases
- 2) Pump work ( $W_P$ ) =  $h_6 - h_5$  increases
- 3) Net Work =  $W_T - W_P$  increases

4) Heat supplied =  $(h_1 - h_6) + (h_3 - h_2)$  increases

### 5.3.4 Regenerative Cycle :-

In a simple Rankine cycle, a significant amount of heat is added for sensible heating of compressed liquid coming out the pump. The mean temperature at which sensible heat added is much lower than source temperature. Thus, the efficiency of the Rankine cycle is much lower than that of Carnot vapour power cycle. The efficiency of Rankine cycle can be improved by heating the feed water regeneratively.

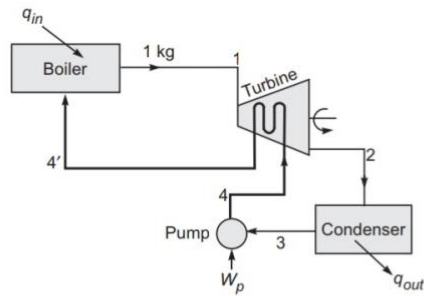

(a) Schematic of ideal regenerative cycle

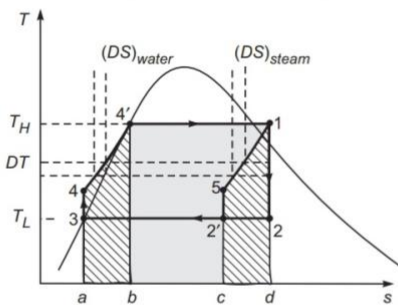

(b) Ideal regenerative cycle on T-s plot

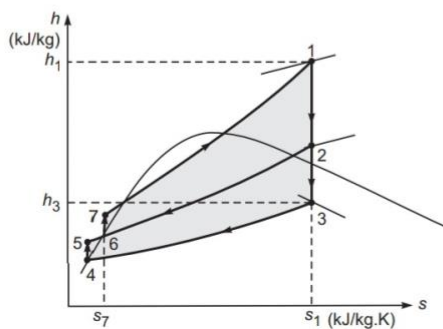

Then  $q_{in} = h_1 - h_4 = T_H (s_1 - s_4')$

and  $q_{out} = h_2' - h_3 = T_L (s_2' - s_3)$

Since  $s_1 - s_4' = s_2' - s_3$

$$\therefore \eta_{Reg} = 1 - \frac{q_{out}}{q_{in}} = 1 - \frac{T_L}{T_H}$$

---

Thus efficiency of an ideal regenerative cycle is thus equal to efficiency of the Carnot cycle .

## 5.4 Solve simple numerical on Carnot vapour cycle & Rankine Cycle

Q .1 A steam power plant operates on the Carnot cycle using dry steam at 17.5 bar. The exhaust takes place at 0.075 bar into condenser. The steam consumption is 20 kg/min.

Calculate:

The efficiency of the cycle ?

ANS:-

**Given :-** A steam power plant operating on Carnot cycle

$p_1 = 17.5 \text{ bar}$  ,  $p_2 = 0.075 \text{ bar}$

$m_s = 20 \text{ kg/min}$

**To Find :-**

- (i) Power developed, and
- (ii) Thermal efficiency of the cycle.

Analysis Properties of steam

At boiler pressure from Table A-12

$P_1 = 17.5 \text{ bar} = 1750 \text{ kPa}$

$T_H = 205.76^\circ\text{C} = 478.77 \text{ K}$

$h_4 = h_f = 878.48 \text{ kJ/kg}$

$h_1 = h_g = 2796.43 \text{ kJ/kg}$

At condenser pressure from Table A-12,

$$P_2 = 0.075 \text{ bar} = 7.5 \text{ kPa}$$

$$T_L = 40.29^\circ\text{C} = 313.3 \text{ K}$$

The heat supplied in the cycle

$$Q_{in} = h_1 - h_4 = 2796.43 - 878.48 \\ = 1917.95 \text{ kJ/kg}$$

The Carnot efficiency is given as =

The thermal efficiency of the cycle;

$$\eta_{Carnot} = \frac{w_{net}}{q_{in}} = \frac{(T_H - T_L)(s_1 - s_4)}{T_H(s_1 - s_4)} \\ = 1 - \frac{T_L}{T_H}$$

$$= 1 - (313.3/478.77)$$

$$= 0.3456 \text{ or } 34.56\%$$

**Q 2.** A steam power plant has boiler and condenser pressures of 60 bar and 0.1 bar, respectively. Steam coming out of the boiler is dry and saturated. The plant operates on the Rankine cycle. Calculate thermal efficiency ?

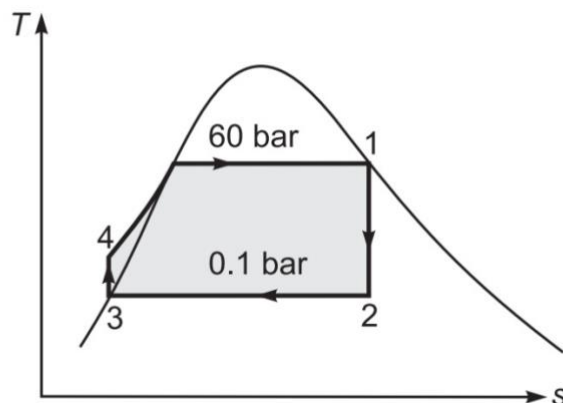

**Ans:-**

Given :- Rankine cycle with dry saturated steam

$$P_1 = 60 \text{ bar} = 6000 \text{ kPa},$$

$$P_2 = 0.1 \text{ bar} = 10 \text{ kPa}$$

To find :-

Thermal efficiency of steam power plant.

Analysis Properties of steam at principal states

State 1:

Dry saturated steam; from Table A-13

$$P_1 = 6000 \text{ kPa},$$

$$h_1 = 2785.10 \text{ kJ/kg}$$

$$S_1 = 5.8891 \text{ kJ/kg} \diamond \text{ K}$$

State 2 :

Wet steam;

$$P_2 = 10 \text{ kPa}$$

$$h_{f2} = 191.81 \text{ kJ/kg}$$

$$h_{fg2} = 2392.82 \text{ kJ/kg}$$

$$S_{f2} = 0.6492 \text{ kJ/kg} \diamond \text{ K}$$

$$S_{fg2} = 7.5010 \text{ kJ/kg} \diamond \text{ K}$$

State 3:

Saturated liquid;

$$P_3 = 0.1 \text{ bar} = 10 \text{ kPa}$$

$$h_3 = h_{f3} = 191.81 \text{ kJ/kg}$$

$$v_{f3} = 0.001010 \text{ m}^3/\text{kg}$$

State 4:

Compressed liquid;

$$p_4 = 6000 \text{ kPa},$$

The state 2, after isentropic expansion can be defined

by equating entropy at states 1 and 2;

$$s_1 = s_2 = (s_f + x s_{fg}) @ 10 \text{ kPa}$$

$$5.8891 = 0.6492 + x (7.5010)$$

$$\text{or } x = (5.8891 - 0.6492) / 7.5010$$

$$= 0.698$$

Specific enthalpy at the state 2

$$h_2 = (h_{f2} + x h_{fg2}) @ 10 \text{ kPa}$$

$$= 191.81 + 0.698 \times 2392.82$$

$$= 1863.34 \text{ kJ/kg}$$

The pump work:-

$$w_p = v_f (p_1 - p_2) = 0.001010 \times (6000 - 10) \\ = 6.05 \text{ kJ/kg}$$

Enthalpy at the state 4;

$$h_4 = h_3 + w_p = 191.81 + 6.05 = 197.86 \text{ kJ/kg.}$$

Rankine cycle efficiency =

$$\eta_{Rankine} = \frac{q_{in} - q_{out}}{q_{in}} = 1 - \frac{q_{out}}{q_{in}} \\ = 1 - \frac{h_2 - h_3}{h_1 - h_4} .$$

$$= 1 - (1863.34 - 191.81) / (2785.10 - 197.86)$$

$$= 0.353 \text{ or } 35.35\%$$

**Q.3** An steam power plant operates on a theoretical reheat cycle. The steam from boiler at 150 bar and 550°C expands through the high-pressure turbine. It is reheated at constant pressure of 40 bar to 550°C and expands through the low pressure turbine to a condenser pressure of 0.1 bar. Draw T –s and h –s diagrams and find  
(a) quality of steam at turbine exhaust,  
(b) Thermal efficiency of the cycle,  
(c) Steam rate in kg/kWh.

**ANS:-**

Example 10.10

**Given** A reheat Rankine cycle with

$$p_1 = 150 \text{ bar} \quad T_1 = 550^\circ\text{C}$$

$$p_2 = 40 \text{ bar} \quad T_3 = 550^\circ\text{C}$$

$$p_3 = 0.1 \text{ bar}$$

**To Find**

- (i) Quality of steam at turbine exhaust,

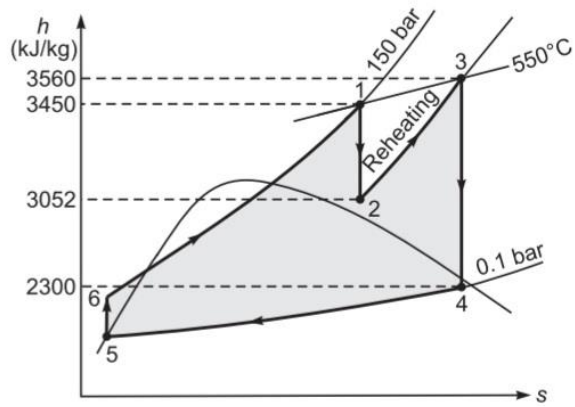
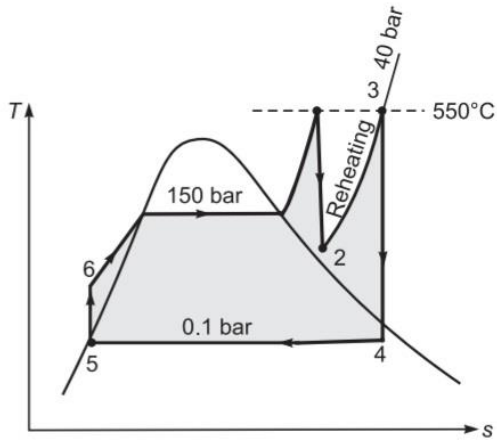

- (ii) Thermal efficiency of the cycle, and
- (iii) Steam rate in kg/kWh.

**Properties of steam** From Mollier chart

At state 1: Superheated steam

$$\begin{aligned} p_1 &= 150 \text{ bar} \\ T_1 &= 550^\circ\text{C} \\ h_1 &= 3450 \text{ kJ/kg} \end{aligned}$$

State 2: After isentropic expansion, the steam is also superheated

$$\begin{aligned} p_2 &= 40 \text{ bar} \\ T_2 &= 335^\circ\text{C} \\ h_2 &= 3052 \text{ kJ/kg} \end{aligned}$$

State 3: Superheated steam

$$\begin{aligned} p_2 &= 40 \text{ bar} \\ T_3 &= 550^\circ\text{C} \\ h_3 &= 3560 \text{ kJ/kg} \end{aligned}$$

State 4: Wet steam

$$\begin{aligned} p_3 &= 10 \text{ kPa} \\ x_4 &= 0.88 \\ h_4 &= 2300 \text{ kJ/kg} \end{aligned}$$

State 5: Saturated liquid (from saturated steam table)

$$\begin{aligned} p_3 &= 10 \text{ kPa} \\ v_f &= 0.001010 \text{ m}^3/\text{kg} \\ h_f &= 191.83 \text{ kJ/kg} \end{aligned}$$

State 6: Compressed liquid  $p_1 = 150 \text{ bar}$

**Analysis**

- (i) *Quality of steam at turbine exhaust*

Using Mollier ( $h-s$ ) chart; draw a vertical straight line 3–4 from point 3 (coordinates: 40 bar and  $550^\circ\text{C}$ ) to a pressure line of 0.1 bar as shown in  $h-s$  diagram of Fig. 12.26. The quality of steam at intersection point 4 as

$$x = \mathbf{0.88}$$

- (ii) *Thermal efficiency of the cycle*

The pump work;

$$\begin{aligned} w_p &= v_f(p_1 - p_3) \\ &= 0.001010 \times (150 \times 10^2 - 10) \\ &= 15.14 \text{ kJ/kg} \end{aligned}$$

Enthalpy at the state 6;

$$\begin{aligned} h_6 &= h_5 + w_p \\ &= 191.93 + 15.14 = 206.97 \text{ kJ/kg} \end{aligned}$$

The heat supplied per kg of steam

$$\begin{aligned} q_{in} &= h_1 - h_6 + h_3 - h_2 \\ &= 3450 - 206.97 + 3560 - 3052 \\ &= 3751.03 \text{ kJ/kg} \end{aligned}$$



Turbine work per kg of steam;

$$\begin{aligned}w_T &= h_1 - h_2 + h_3 - h_4 \\ &= 3450 - 3052 + 3560 - 2300 \\ &= 1658 \text{ kJ/kg}\end{aligned}$$

$$\begin{aligned}w_{net} &= w_T - w_p = 1658 - 15.14 \\ &= 1642.86 \text{ kJ/kg}\end{aligned}$$

Thermal efficiency;

$$\eta_{cycle} = \frac{w_{net}}{q_{in}} = \frac{1642.86}{3751.03} = 0.438 \text{ or } \mathbf{43.8\%}$$

(iii) *Steam rate in kg/kWh*

$$\begin{aligned}ssc &= \frac{3600}{w_{net}} = \frac{3600}{1642.86} \\ &= \mathbf{2.19 \text{ kg/kWh}}\end{aligned}$$

## QNA CHAPTER-5

### Short ans type questions

Q.1 What is thermal efficiency of any steam power cycle ?

Ans:-

**Thermal Efficiency-** The thermal efficiency of any power cycle is expressed as

$$\begin{aligned}\eta_{th} &= \frac{\text{Net work done in the cycle}}{\text{Heat supplied in the cycle}} \\ &= \frac{W_{net}}{Q_{in}} \quad \dots\end{aligned}$$

2. What do you understand by steam rate ?

Ans:-

It is also called *specific steam consumption* .It relates the power output to amount of steam necessary to produce it .It is the amount of steam required to produce 1kWh(3600kj) of power .It is expressed as **SSC**

1. What do you understand by heat rate ?

Ans:-

∴ It is the amount of heat required by a power plant to produce 1 kWh of power .

$$\begin{aligned}\text{Heat rate} &= \frac{(\text{Heat input in kJ/s}) \times (3600 \text{ s/h})}{\text{Net power output in kW}} \\ &= \frac{3600}{\eta_{th}} (\text{kJ/kWh}) \quad \dots(12)\end{aligned}$$

---

4. Write Carnot efficiency formula ?

Ans:-

The thermal efficiency of the cycle;

$$\begin{aligned}\eta_{Carnot} &= \frac{w_{net}}{q_{in}} = \frac{(T_H - T_L)(s_1 - s_4)}{T_H(s_1 - s_4)} \\ &= 1 - \frac{T_L}{T_H}\end{aligned}$$

2. Write Rankine efficiency formula ?

Ans:-

$$\begin{aligned}\eta_{Rankine} &= \frac{q_{in} - q_{out}}{q_{in}} = 1 - \frac{q_{out}}{q_{in}} \\ &= 1 - \frac{h_2 - h_3}{h_1 - h_4}\end{aligned}$$

$$\begin{aligned}\eta_{th} &= \frac{\text{Net work done in the cycle}}{\text{Heat supplied in the cycle}} \\ &= \frac{w_{net}}{q_{in}}\end{aligned}$$

5. What is Back Work Ratio ?

Ans:- Back Work Ratio is defined as ratio of pump work input to the work developed by the turbine .

$$r_{bw} = \frac{\text{Pump work}}{\text{Turbine work}} = \frac{w_p}{w_T}$$

Q.5 What is Work Ratio ?

Ans:-The work ratio for a power plant is defined as ratio of the net work output of the cycle to the work developed by the turbine .

$$r_w = \frac{\text{Net work output of the cycle}}{\text{Turbine work}}$$
$$= \frac{w_{net}}{w_T} = 1 - bwr \quad \dots$$

### Long Questions

**Q.1** A steam power plant operates on the Carnot cycle using dry steam at 15 bar. The exhaust takes place at 0.065 bar into condenser. The steam consumption is 5000 gm/min.

Calculate:

The efficiency of the cycle ?

Hint:-see numerical Q.1

**Q.2** A steam power plant has boiler and condenser pressures of 70 bar and 0.5 bar, respectively. Steam coming out of the boiler is dry and saturated. The plant operates on the Rankine cycle. Calculate thermal efficiency ?

Hint :-See numerical Q.2 and Steam table

**Q.3** An steam power plant operates on a theoretical reheat cycle. The steam from boiler at 150 bar and 550°C expands through the high-pressure turbine. It is reheated at constant pressure of 40 bar to 550°C and expands through the low pressure turbine to a condenser pressure of 0.1 bar. Draw T –s and h –s diagrams and find

(a) quality of steam at turbine exhaust,

(b) Thermal efficiency of the cycle,

(c) Steam rate in kg/kWh.

Hint - See numerical Q.3 and Steam table

## Chapter 6

# Heat transfer

## 6.1 Modes of Heat Transfer(Conduction ,Convection , Radiation )

### Conduction:-

When temperature gradient exists in a medium which may be a solid, fluid or gas, then there is an energy transfer from high temperature region to low temperature region.

This energy transfer as heat is called heat conduction.

### Convection:-

In contrast, heat convection refers to heat transfer that will occur between a surface and the adjacent moving medium, liquid or gas, when they are at different temperatures. It involves the combined effects of conduction and fluid motion.

### Radiation:-

If there is no fluid motion, then the heat is transferred between a solid and its adjacent fluid by pure conduction. The third mode of heat transfer is thermal radiation.

All surfaces at finite temperature emit energy in the form of electromagnetic waves or (photons) as result of the changes in electron configuration of the atoms or molecules. This mode of heat transfer does not require the presence of a material medium.

The energy transfer by radiation is fastest and it can also travel in vacuum

## 6.2 Fourier law of heat conduction and thermal Conductivity (K)

The rate of heat conduction through a medium depends on its geometry, thickness and material of the medium as well as temperature difference.

The Fourier law states that the rate of heat conduction per unit area (heat flux) is directly proportional to temperature gradient.

$$\frac{\dot{Q}}{A} \propto \frac{dT}{dx}$$

or 
$$q = \frac{\dot{Q}}{A} = -k \frac{dT}{dx}$$

$$\dot{Q} = -kA \frac{dT}{dx}$$

where  $q$  = heat flux ( $\text{W}/\text{m}^2$ )

$\dot{Q}$  = rate of heat transfer, W

$A$  = area normal to direction of heat flow,  
 $\text{m}^2$

$\frac{dT}{dx}$  = temperature gradient  $^{\circ}\text{C}/\text{m}$ , slope of  
temperature curve on  $T$ - $x$  diagram

$k$  = constant of proportionality, called  
*thermal conductivity* of material,  $\text{W}/\text{m}$   
 $^{\circ}\text{C}$  or  $\text{W}/\text{m} \cdot \text{K}$

---

The minus sign is inserted to make natural heat flow a positive quantity. According to the second law of thermodynamics, heat always flows in the direction of decreasing temperature. Thus the temperature gradient  $dT/dx$  becomes negative..

### Thermal conductivity:-

- The thermal conductivity is a property of a material and is defined as the ability of the material to conduct heat through it.
- It can also be defined as the rate of heat transfer through a unit thickness of material per unit area per unit temperature difference.

- The thermal conductivity of a material is a measure of how fast heat will flow in that material. A large value of thermal conductivity
- indicates that the material is a good heat conductor and a low value indicates that the material is a poor heat conductor or an insulator.
- The thermal conductivity is measured in watts per meter per degree Celsius or Watt metre per kelvin, when heat flow rate is expressed in watts.

### 6.3 Newton's law of cooling:-

- The convection heat transfer comprises of two mechanisms. The first is the transfer of energy due to random molecular motion (diffusion), and
- The second is the energy transfer by bulk motion of the fluid. The molecules of fluid are moving collectively or as aggregates and thus carry energy from a high temperature region to a low-temperature region.
- If the fluid motion is artificially induced by a pump, fan or a blower that forces the fluid over a surface to flow, the heat transfer is said to be forced convection.
- If the fluid motion is set up by buoyancy effects resulting from density difference caused by temperature difference in the fluid, the heat transfer is said to be by free (or natural) convection.



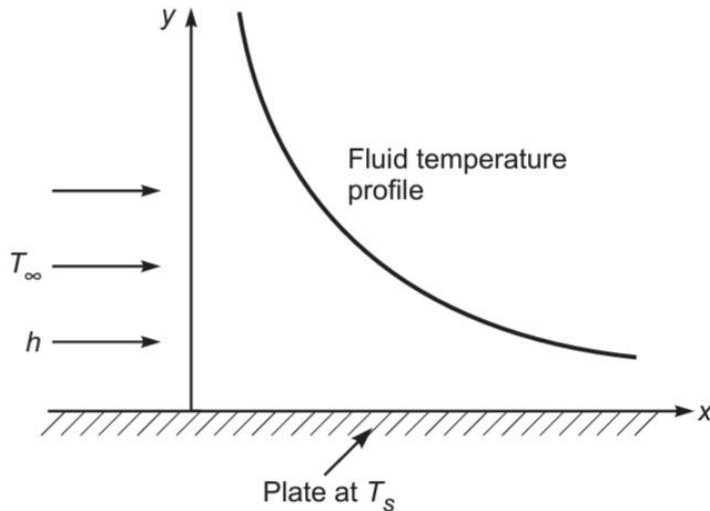

Temperature Profile in Convection

The Newton's law of cooling is the governing equation of convection heat transfer. It states that the rate of heat transfer is directly proportional to temperature difference between a surface and fluid or mathematically

$$\frac{\dot{Q}}{A} \text{ (W/m}^2\text{)} \propto (T_s - T_\infty) \text{ (}^\circ\text{C)}$$

or

$$\frac{\dot{Q}}{A} = h(T_s - T_\infty)$$

where,  $T_s$  = surface temperature,  $^\circ\text{C}$

$T_\infty$  = fluid temperature,  $^\circ\text{C}$

$h$  = constant of proportionality, is called the heat transfer coefficient.

The heat transfer coefficient is measured in  $\text{W/m}^2 \text{ K}$  or  $\text{W/m}^2 \text{ }^\circ\text{C}$ . The value of the heat transfer coefficient depends on the properties of fluid as well as fluid flow conditions

## 6.4 Radiation heat transfer.(Stefan–Boltzmann Law & Kirchhoff's Law ):-

### Radiation heat transfer : Stefan–Boltzmann Law

When energy propagates in the form of electromagnetic waves from a high-temperature region to a low-temperature region, the form of energy transfer is referred as thermal radiation. Stefan–Boltzmann law governs the radiation heat transfer. It states that the rate of radiation heat transfer per unit area from a black surface is directly proportional to fourth power of the absolute temperature of the surface and is given by

$$\frac{\dot{Q}}{A} \propto (T^4)$$

or

$$\frac{\dot{Q}}{A} = \sigma T_s^4$$

---

where  $T_s$  = absolute temperature of surface K  
 $\sigma$  = constant of proportionality, called *Stefan Boltzmann Constant* and has value of  $5.67 \times 10^{-8} \text{ W/m}^2 \text{ K}^4$

---

The heat flux emitted by a real surface is less than that of black surface and is given by

$$\frac{\dot{Q}}{A} = \sigma \epsilon (T_s^4)$$

where,  $\epsilon$  a radiative property of the surface is called the emissivity .

The net rate of radiation heat exchange between a real surface and its surrounding is

$$\frac{\dot{Q}}{A} = \sigma \varepsilon (T_s^4 - T_\infty^4) \quad \dots$$

where,  $T_\infty$  = surrounding temperature K  
 $T_s$  = surface temperature, K

The three other radiation laws, Planck's law, Wein's law and Kirchhoff's law, are also used in radiation heat transfer.

### Kirchhoff's Law :-

It states that at thermal equilibrium, the ratio of the spectral emissive power to spectral absorptivity for all bodies is constant or

$$\frac{E_{\lambda 1}}{\alpha_{\lambda 1}} = \frac{E_{\lambda 2}}{\alpha_{\lambda 2}} = \frac{E_{\lambda 3}}{\alpha_{\lambda 3}} = \frac{E_{\lambda b}}{\alpha_{\lambda b}} = C$$

Since  $\alpha_{\lambda b} = 1$

$$\frac{E_{\lambda 1}}{E_{\lambda b}} = \alpha_{\lambda 1}$$

or  $E_{\lambda 1} = \alpha_{\lambda 1} E_{\lambda b}$

Similarly, for other bodies, it can be shown that at thermal equilibrium, the energy emitted by a surface must be equal to energy absorbed by the surface. Hence, spectral emissivity is equal to spectral absorptivity at thermal equilibrium. This law is applicable when the radiation properties are independent of wavelength (for gray bodies) or when incident and emitted radiation have the spectral distribution.

## 6.5 Black body Radiation , Definition of Emissivity ,Absorptivity ,& Transmissibility :-

### Black body Radiation:-

It is an ideal surface having the following properties:

1. A black body absorbs all incident radiation from all directions at all wavelengths.
2. At any temperature and wavelength, nobody can emit energy more than a black body.
3. Although the radiation emitted by a black body depends upon wavelength and temperature, it is independent of direction.
4. A black body neither reflects nor transmits any amount of incident radiation.

Consider a radiation beam entering the cavity of an enclosure as shown in Fig. bellow . It experiences many reflections within the enclosure and almost entire beam is absorbed by the cavity and the black body behaviour is experienced.

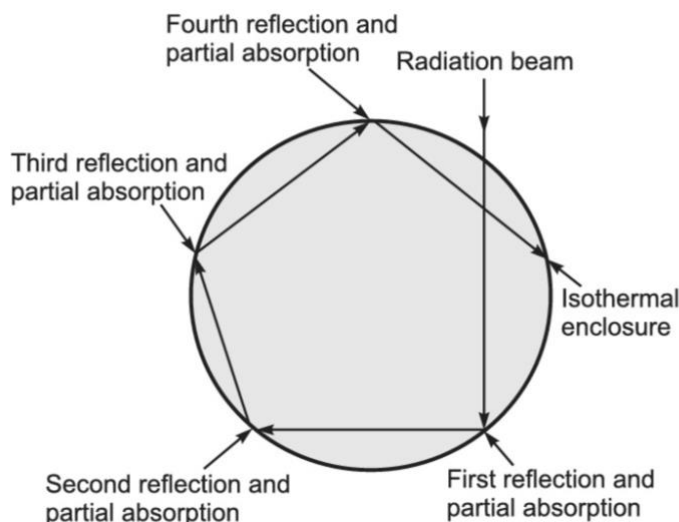

## Definition of Emissivity :-

It is the ratio of radiation heat flux emitted by a real surface at a temperature  $T$ , over all wavelengths into hemispherical space, to that which would have been emitted by a black body at same temperature.

Mathematically

$$\varepsilon = \frac{E}{\int_0^{\infty} E_{b\lambda} d\lambda} = \frac{E}{E_b}$$

For real surfaces, the emissive power

$$E = \varepsilon E_b = \varepsilon \sigma T^4$$

## Absorptivity:-

A black body absorbs all incident radiation, hence its absorptivity is considered unity. But real surfaces do not absorb all energy incident on it.

The total or average or hemispherical absorptivity  $\alpha$  is defined as fraction of radiation energy incident on the surface from all directions, over entire wavelength spectrum, that is absorbed by the surface.

Mathematically,

$$\alpha = \frac{G_a}{G}$$

where,

$G_a$  = Energy absorbed by the surface,  $W/m^2$

$G$  = Irradiation,  $W/m^2$

## Transmissibility:-

When a radiation beam is incident on a semitransparent surface, a part is reflected, a part is absorbed and the remaining is transmitted. Hence, transmissivity is the fraction of incident energy transmitted through the surface.

Mathematically

$$\tau = \frac{G\tau}{G}$$

and for average properties:

$$\alpha + \rho + \tau = 1$$

---

## QNA CH.6

### Short Question

Q.1 What is Conduction ?

ANS :-

When temperature gradient exists in a medium which may be a solid, fluid or gas, then there is an energy transfer from high temperature region to low temperature region.

This energy transfer as heat is called heat conduction.

Q.2 What is Radiation ?

Ans:-

Thermal radiation refers to the heat energy emitted by the bodies because of their temperatures.

All bodies at a temperature above absolute zero temperature emit thermal radiation.

For example, the energy emitted by sun travels through space and reaches the earth surface. The energy transfer by radiation does not require any medium between hot and cold surfaces. In fact, the radiation heat transfer is more effective in vacuum

Q.3 Define Thermal conductivity ?

Ans:-

The thermal conductivity is a property of a material and is defined as the ability of the material to conduct heat through it.

Q.4 What is Convection ?

Ans:-

In contrast, heat convection refers to heat transfer that will occur between a surface and the adjacent moving medium, liquid or gas, when they are at different temperatures. It involves the combined effects of conduction and fluid motion.

Q.5 Write is Absorptivity ?

Ans:-

A black body absorbs all incident radiation, hence its absorptivity is considered unity. But real surfaces do not absorb all energy incident on it.

The total or average or hemispherical absorptivity  $\alpha$  is defined as fraction of radiation energy incident on the surface from all directions, over entire wavelength spectrum, that is absorbed by the surface.

Mathematically,

$$\alpha = \frac{G_a}{G}$$

where,

$G_a$  = Energy absorbed by the surface,  $W/m^2$

$G$  = Irradiation,  $W/m^2$

### Long Question

Q.1 Write a short notes on Black body Radiation ?

Ans:- See Article 6.5

Q.2 Define Fourier law of heat conduction ?

ANS:- See Article 6.2



Q .3 Short notes on Newton's law of cooling ?

ANS:- See Article 6.3

Q.4 Write down the Stefan–Boltzmann Law and Kirchhoff's Law?

**Ans:-** See Article 6.4









